

## TORQUE SPECIFICATIONS

DESCRIPTION	N·m	Ft. Lbs.	In. Lbs.	COMMENT
Front Driveshaft to Front Axle Flange Bolts	121	89	—	Do not reuse these fasteners. If removed, a <b>NEW</b> fastener must be installed and tightened to specifications. Torque and secure in a crisscross pattern.
Front Driveshaft to Transfer-Case Flange Bolts	39	29	—	Do not reuse these fasteners. If removed, a <b>NEW</b> fastener must be installed and tightened to specifications. Torque and secure in a crisscross pattern.
Rear Driveshaft to Transfer-Case Flange Bolts	39	29	—	Do not reuse these fasteners. If removed, a <b>NEW</b> fastener must be installed and tightened to specifications. Torque and secure in a crisscross pattern.

DESCRIPTION	N·m	Ft. Lbs.	In. Lbs.	COMMENT
Rear Driveshaft to Rear Axle Flange Bolts	39	29	—	Do not reuse these fasteners. If removed, a <b>NEW</b> fastener must be installed and tightened to specifications. Torque and secure in a crisscross pattern.
Rear Driveshaft Carrier Bearing to Frame	62	46	—	—

Identify the proper CV joint bolt configuration, four or eight bolts, and begin with the first bolt referred to as “1”, follow the torque sequence as indicated. In the case where there are two numbers shown for a given bolt it indicates the bolt is to be torqued again within the sequence.

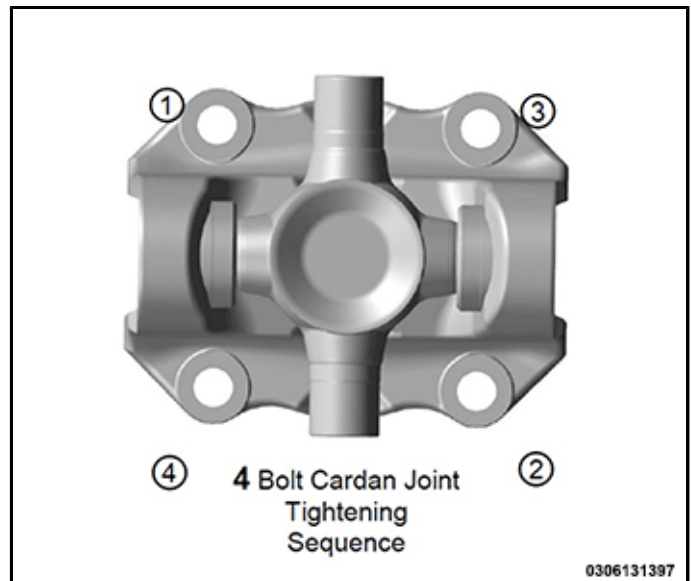
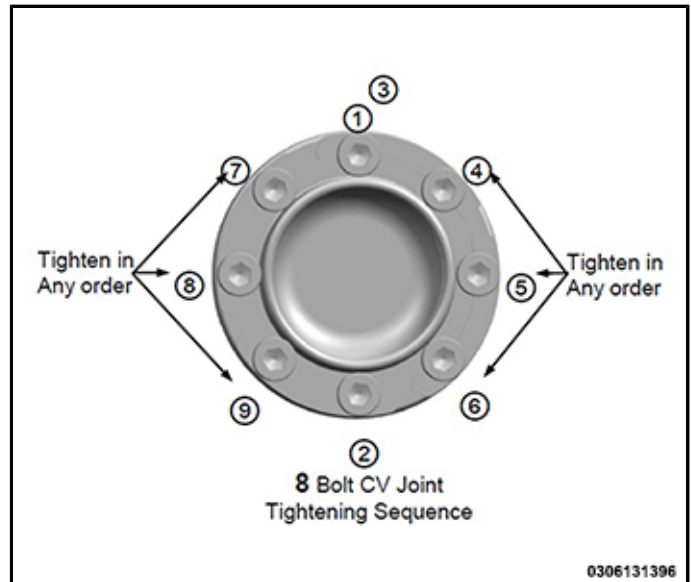

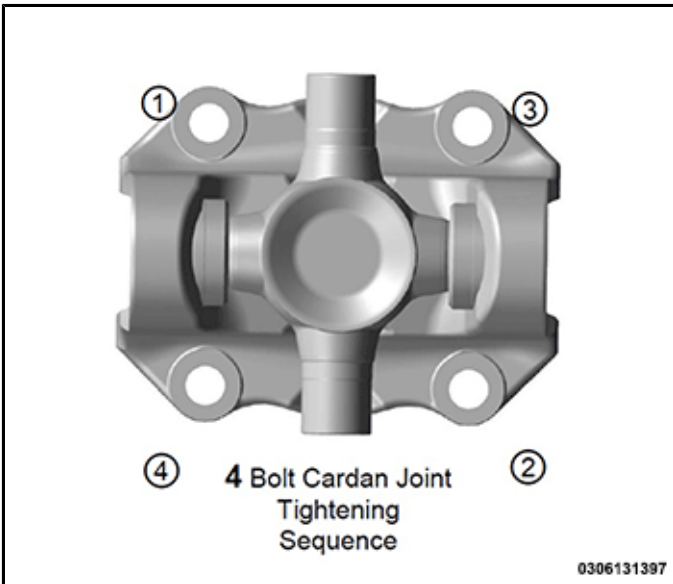

Identify the proper CV joint bolt configuration, four or eight bolts, and begin with the first bolt referred to as “1”, follow the torque sequence as indicated. In the case where there are two numbers shown for a given bolt it indicates the bolt is to be torqued again within the sequence.

03 - Differential and Driveline/Driveshaft/Removal and Installation

**FRONT**

Primary LOP	Related LOP	Description	Skill Level	Skill Category
16 30 01 03	-	Propeller shaft, with universal joints Transfer case to front axle	1 - Semi Skilled	3
16 30 01 04	-	Propeller shaft, with universal joints Transfer Case to Rear Axle	1 - Semi Skilled	3
16 30 01 06	-	Propeller shaft, with universal joints Rear, two piece shaft	1 - Semi Skilled	3
16 30 03 13	-	Reindex propeller shaft Transfer case to front axle	1 - Semi Skilled	3
16 30 03 14	-	Reindex propeller shaft Transfer case to rear axle	1 - Semi Skilled	3
16 30 10 03	-	Yoke, propeller shaft sliding Transfer case to front axle	1 - Semi Skilled	3
16 30 10 04	-	Yoke, propeller shaft sliding Transfer case to rear axle	1 - Semi Skilled	3

**REMOVAL**

1. Raise and support the vehicle (Refer to 04 - Vehicle Quick Reference/Hoisting/Standard Procedure).
2. Remove and **DISCARD** the front driveshaft to transfer case bolts (1).

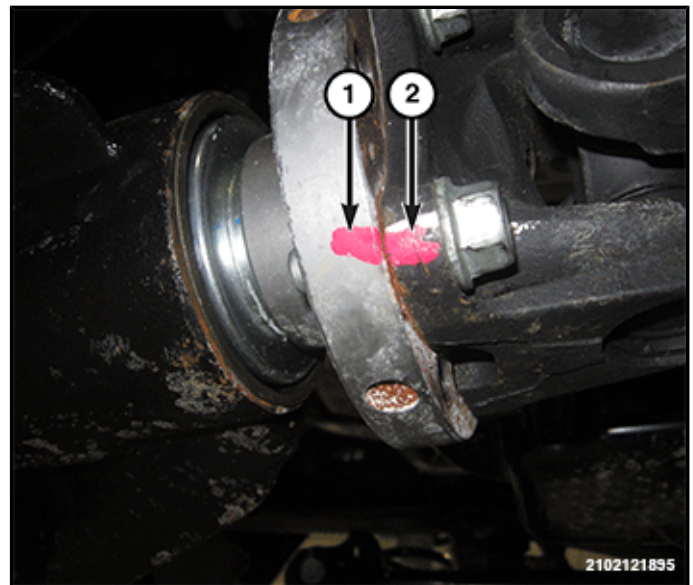

3. Mark an installation reference line across the front driveshaft flange (2) and the axle pinion flange (1). Mark an installation reference line at the front driveshaft flange and transfer case output flange also for re-assembly.

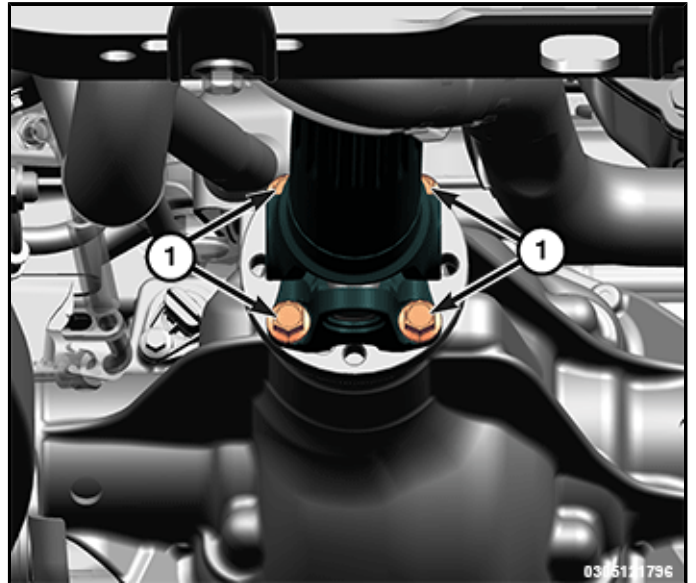

4. Remove and **DISCARD** the front axle flange to front driveshaft bolts (1) and remove the driveshaft.

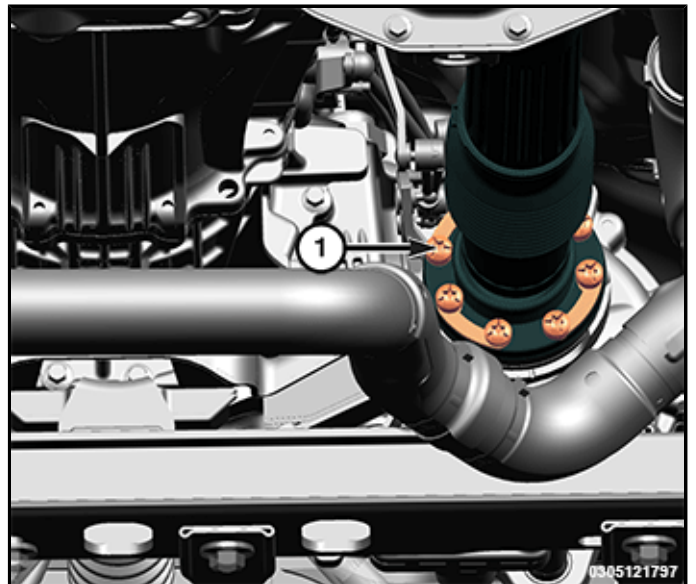

## INSTALLATION

1. Position the front driveshaft in the vehicle and align the driveshaft alignment marks (2) to the front axle pinion flange (1) and transfer case output flange.

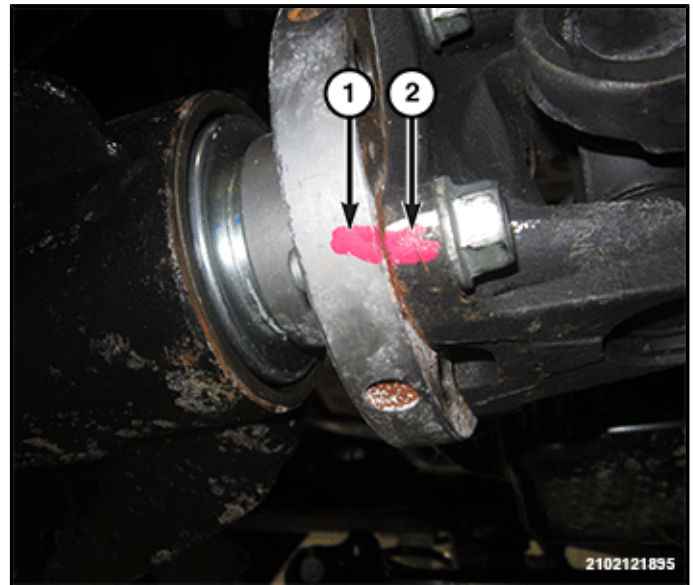

2. Install the **NEW** front driveshaft to transfer case bolts (1) and tighten to the proper (Torque Specifications).

**NOTE:** Drive shaft bolts must be replaced with **NEW** . If **NEW** bolts are not available clean the old bolts and apply Mopar® Lock and Seal Adhesive or equivalent.

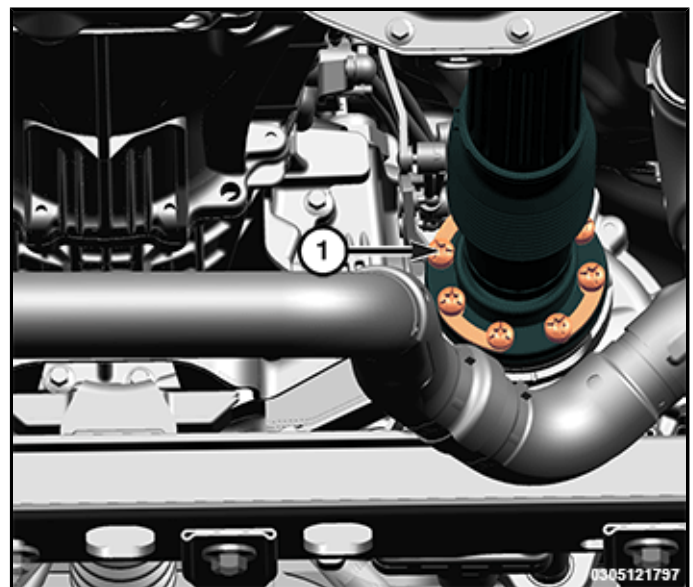

3. Install the **NEW** front driveshaft to axle pinion flange bolts (1) and tighten to the proper (Torque Specifications).

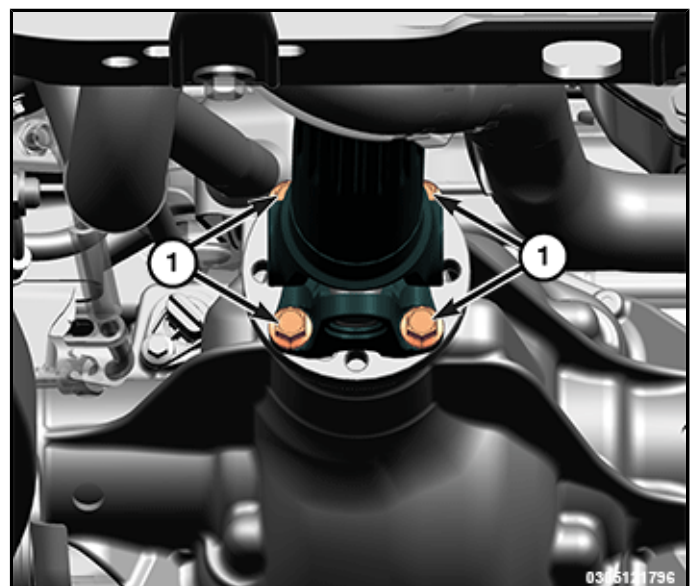

4. Remove the support and lower the vehicle.

03 - Differential and Driveline/Driveshaft/Removal and Installation

**REAR**

Primary LOP	Related LOP	Description	Skill Level	Skill Category
16 30 01 03	-	Propeller shaft, with universal joints Transfer case to front axle	1 - Semi Skilled	3
16 30 01 04	-	Propeller shaft, with universal joints Transfer Case to Rear Axle	1 - Semi Skilled	3
16 30 01 06	-	Propeller shaft, with universal joints Rear, two piece shaft	1 - Semi Skilled	3
16 30 03 13	-	Reindex propeller shaft Transfer case to front axle	1 - Semi Skilled	3
16 30 03 14	-	Reindex propeller shaft Transfer case to rear axle	1 - Semi Skilled	3
16 30 10 03	-	Yoke, propeller shaft sliding Transfer case to front axle	1 - Semi Skilled	3
16 30 10 04	-	Yoke, propeller shaft sliding Transfer case to rear axle	1 - Semi Skilled	3

**REMOVAL**

1. Raise and support the vehicle (Refer to 04 - Vehicle Quick Reference/Hoisting/Standard Procedure).
2. Index mark the driveshaft to pinion flange union for installation purposes. Mark the driveshaft with an arrow for installation direction reference.
3. Using a long piece of wood or similar, fasten it to the driveshaft with several cable ties in order to keep the driveshaft from over-articulating during removal and installation.



0305162157

4. Remove and **DISCARD** the rear driveshaft to pinion flange bolts (1) and shims.

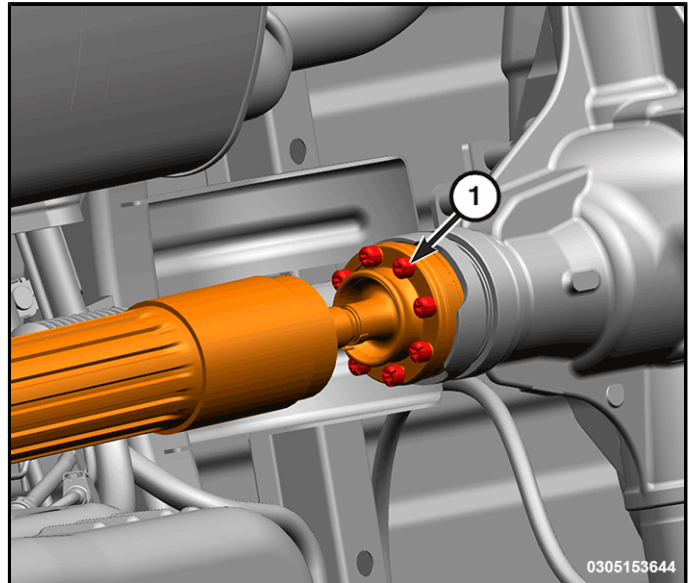

5. Index mark the driveshaft to transfer case flange for installation purposes.
6. Remove and **DISCARD** the driveshaft to transfer case flange bolts (1).

**CAUTION:** Driveshaft removal is a two-person operation. Never allow the driveshaft to hang from the center bearing, or while only connected to the transmission or rear axle flanges. An assistant is required. If a driveshaft section is hung unsupported, damage may occur to the shaft, joint and center bearing from over-angulation. This may result in driveline vibrations or component failure.

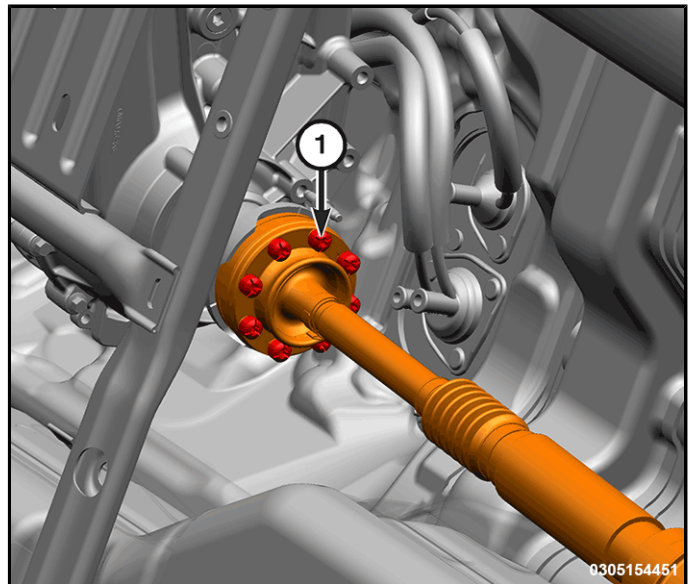

7. Remove the two center support bearing bolts (1) and remove the driveshaft from the vehicle.

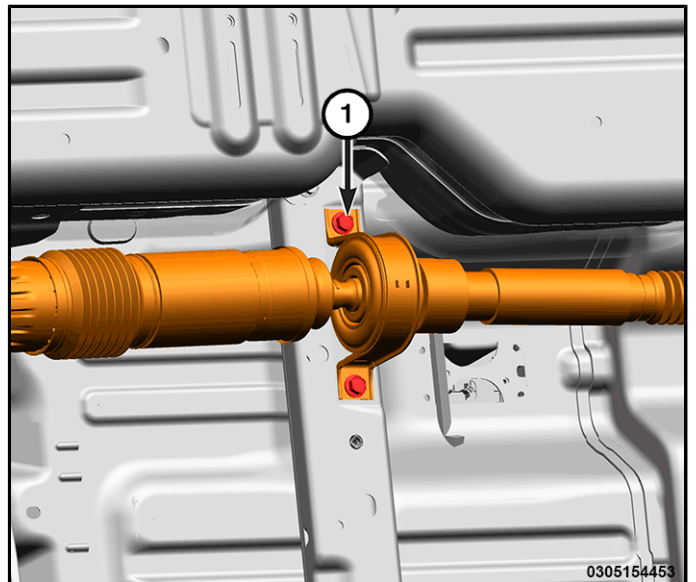

8. Inspect the driveshaft for damage, replace as necessary.
9. Inspect the transfer case flange and the rear axle flange for damage and replace as necessary.

## INSTALLATION

1. Align the driveshaft splines to the transfer case tail shaft splines, then place the driveshaft into the vehicle and install the two center support bearing bolts (1). Tighten to proper (Torque Specifications).
2. Align the index marks made during removal and position the driveshaft in place.
3. Install the **NEW** driveshaft to transfer case flange shims and bolts (1). Tighten to the proper (Torque Specifications).

### NOTE:

**Drive shaft bolts must be replaced with NEW bolts. If NEW bolts are not available clean the old bolts and apply Mopar® Lock and Seal Adhesive or equivalent.**

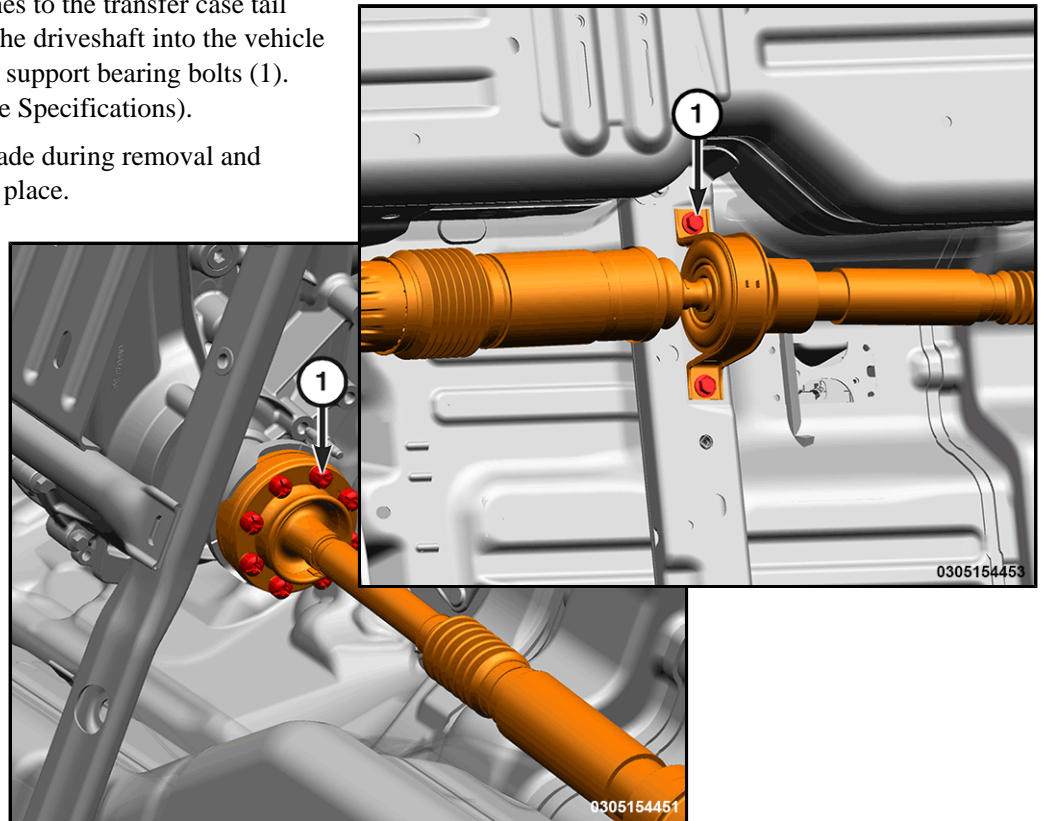

4. Align the index marks made during removal and position the driveshaft in place.

5. Install the **NEW** driveshaft to pinion flange shims and bolts (1), Tighten to the proper (Torque Specifications).

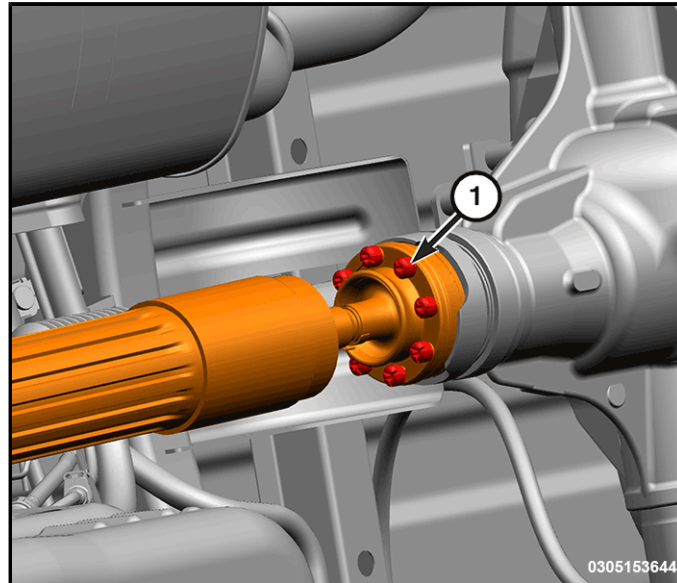

6. Remove the cable ties holding the wood to the driveshaft and remove the wood brace.
7. Remove the support and lower the vehicle.