

03 - Differential and Driveline/Front Axle - M210/ACTUATOR, Axle Locker/Removal and Installation

REMOVAL AND INSTALLATION

Labor Operations: Click to hide the list of LOPs associated with this procedure

No LOP information available for this service procedure.

Special Tools: Click to hide the list of tools used in this procedure

[Click here to launch the form to order any tools you need.](#)

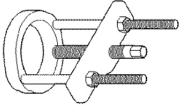
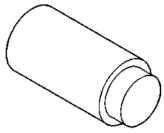
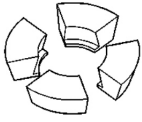
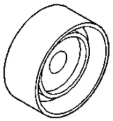
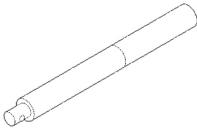
	<p style="text-align: center;">C-293-PA - Puller, Press</p> <p style="text-align: center;">Originally Shipped In Kit Number(s) 8418, 8837, C-293-M.</p>
	<p style="text-align: center;">C-293-3 - Adapter, Bearing/Gear</p> <p style="text-align: center;">Originally Shipped In Kit Number(s) 8418, 8837, C-293-M, C-4246-AL, DD-914-CLT-L.</p>
	<p style="text-align: center;">C-293-47 - Block Set, Puller</p> <p style="text-align: center;">Originally Shipped In Kit Number(s) 9975, C-293-M, DD-914-CLT-L.</p>
	<p style="text-align: center;">C-4213 - Installer, Bearing</p> <p style="text-align: center;">Originally Shipped In Kit Number(s) 9685, 9695, 9720-SUP, 9945-SUP2, 9995.</p>
	<p style="text-align: center;">C-4171 - Driver Handle, Universal</p> <p style="text-align: center;">Originally Shipped In Kit Number(s) 9202, 9202A-CAN, 9202CC, 9299, 9299CC, 9299CC, 9300A-CAN.</p>

REMOVAL

1. Remove the differential assembly from the axle housing (Refer to 03 - Differential and Driveline/Front Axle/CASE ASSEMBLY, Differential, TRU-LOK/Removal and Installation) .
2. Remove the bearing from the actuator side of the differential case (3) using the C-293-PA (1), Plug C-293-3 , and C-293-47 (2).

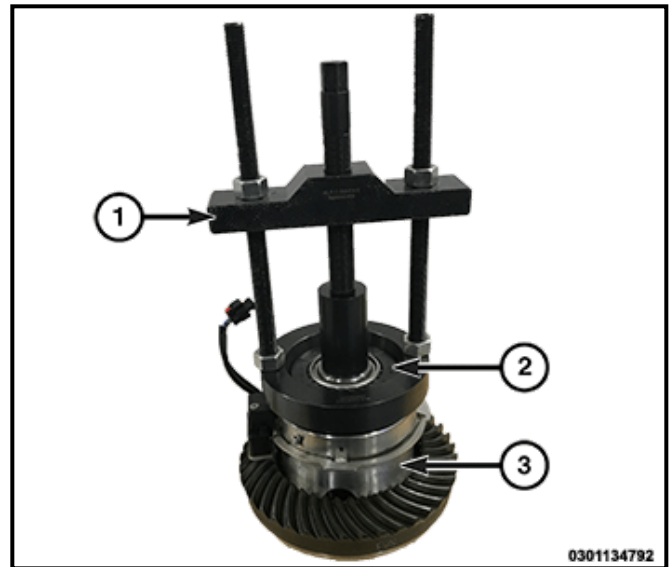

3. Remove the actuator (1) from the pressure plate (2) and from the differential case (3).

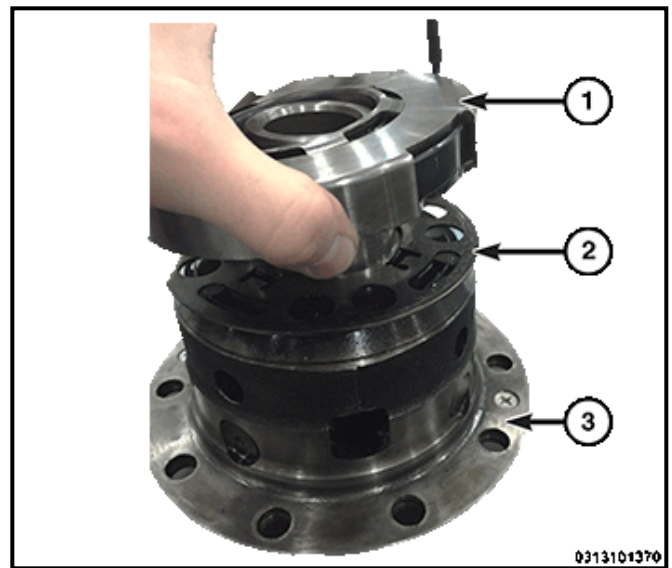

INSTALLATION

1. Place the pressure plate (1) onto the differential case.
Align the tabs of the pressure plate to the differential case.

NOTE:
Shown without ring gear installed.

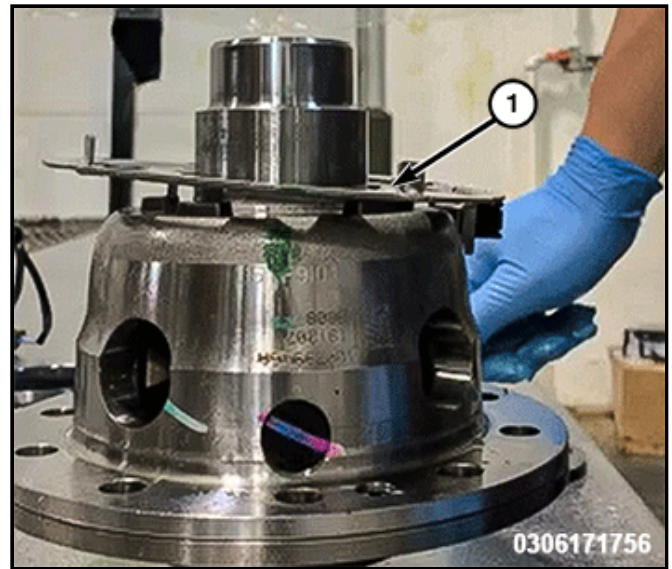

2. Place the spacer (1) inside the pressure plate.

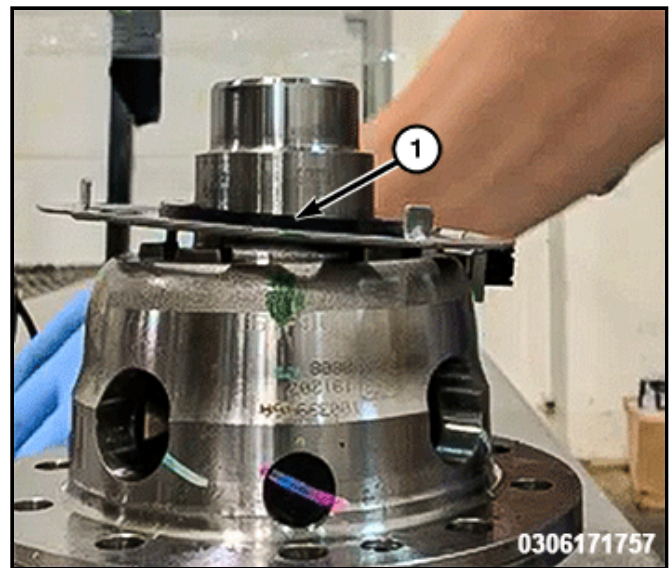

3. With the actuator (1) upside-down, press the pressure plate onto the differential case using hand pressure.



4. Remove the spacer (1) from the pressure plate.

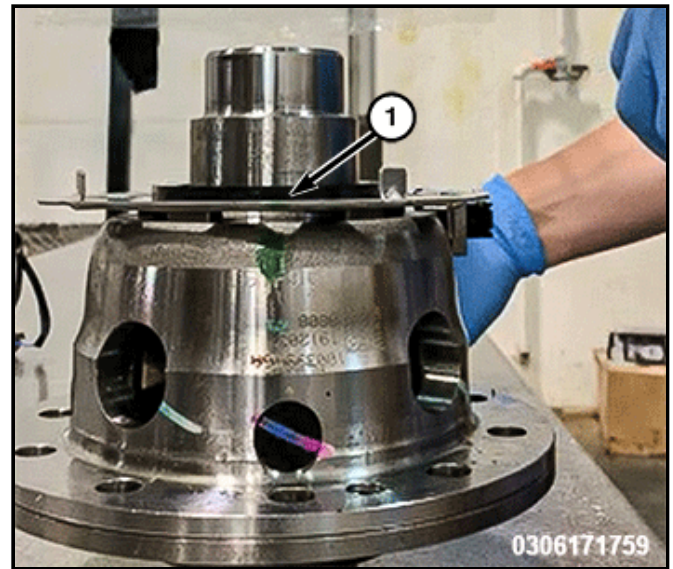

5. Install the spacer on the actuator.

6. Orient the actuator (1) with the alignment tab (2) on the pressure plate.



7. Seat the actuator (1) on the pressure plate.



8. Install the differential side bearing (3) using the C-4213 (2) and handle C-4171 (1).

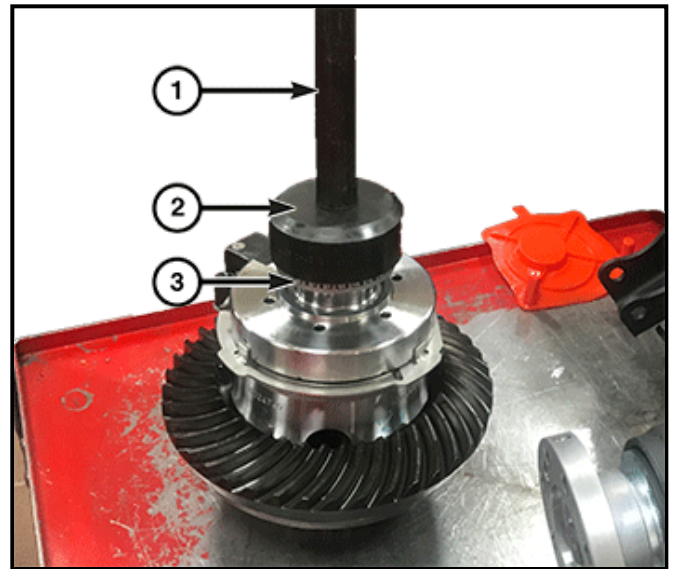

9. Install the differential assembly into the axle housing (Refer to 03 - Differential and Driveline/Front Axle/CASE ASSEMBLY, Differential, TRU-LOK/Removal and Installation) .