

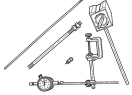

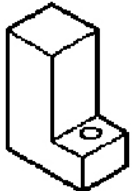





03 - Differential and Driveline/Front Axle - M210/Adjustments

ADJUSTMENTS

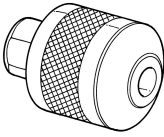
Special Tools: Click to hide the list of tools used in this procedure

[Click here to launch the form to order any tools you need.](#)

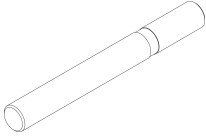
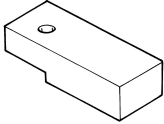
	<p style="text-align: center;">C-3339A - Set, Dial Indicator Originally Shipped In Kit Number(s) <i>9202.</i></p>
	<p style="text-align: center;">6739 - Block, Height Originally Shipped In Kit Number(s) <i>6730, 9516A-CAN, 9540, 9541.</i></p>
	<p style="text-align: center;">2053200030 - Gauge, Pinion Height 38.800 mm</p>
	<p style="text-align: center;">2053300030 - Gauge, Pinion Height 24.800 mm</p>
	<p style="text-align: center;">6741 - Screw Originally Shipped In Kit Number(s) <i>6730, 6731, 9516A-CAN, 9540, 9541.</i></p>
	<p style="text-align: center;">6740 - Cone Originally Shipped In Kit Number(s) <i>6730, 6731, 9516A-CAN, 9540, 9541.</i></p>
	<p style="text-align: center;">2052800030 - Set, Arbor Disc</p>
	<p style="text-align: center;">D-115-3 - Arbor Originally Shipped In Kit Number(s) <i>8667, 9516A-CAN.</i></p>

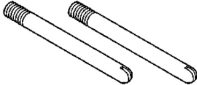
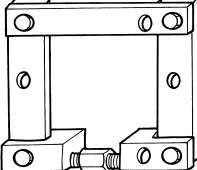
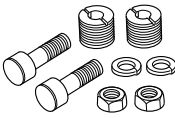
	
	<p>D-115-2A - Block, Scooter</p> <p>Originally Shipped In Kit Number(s) <i>9329-SUP, 9515-SUP, 9516-SUP, 9517-SUP, 9518, 9519, 9540-SUP, 9541-SUP, 9694, 9926.</i></p>
	<p>2052900030 - Bearing, Dummy 80.000 mm</p>
	<p>2053000030 - Bearing, Dummy 77.788 mm</p>
	<p>C-3288-B - Set, Alignment Pins</p> <p>Originally Shipped In Kit Number(s) <i>9975.</i></p>
	<p>W-129-B - Spreader, Differential</p> <p>Originally Shipped In Kit Number(s) <i>9975.</i></p>
	<p>6987B - Adapter Kit, Axle Spreader</p> <p>Originally Shipped In Kit Number(s) <i>6980, 6994, 6995, 8653.</i></p>

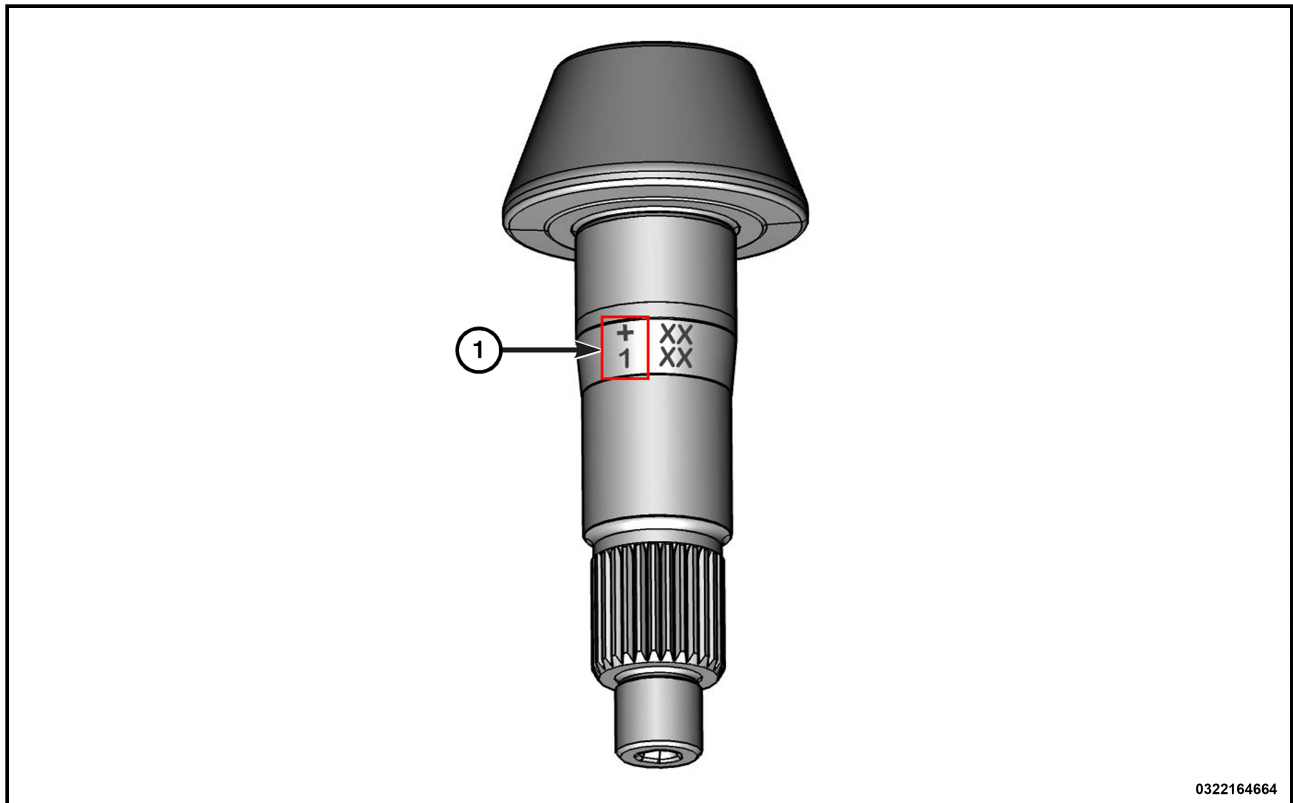

Ring and pinion gears are supplied as matched sets. A plus “+” number, minus “-” number or zero “0” is etched into the shank of the pinion shaft (1). This number is the amount (in hundredths of a millimeter) the depth varies from the standard depth setting of a pinion etched with a “0”. The standard depth provides the best gear tooth contact pattern. Refer to Backlash and Contact Pattern in this section for additional information.

If a new gear set is being installed, note the depth variance etched into both the original and replacement pinion. Add or subtract this number from the thickness of the original depth washer to compensate for the difference in the depth variances. Refer to the Depth Variance chart.

Note where Old and New Pinion Marking columns intersect. Intersecting figure represents plus or minus the amount needed.

Note the etched number on the face of the pinion shaft (-1, -2, 0, +1, +2, etc.). The numbers represent hundredths of a millimeter deviation from the standard. If the number is negative, add that value to the required thickness of the depth washer. If the number is positive, subtract that value from the thickness of the depth washer. If the number is 0 no change is necessary.

PINION GEAR DEPTH VARIANCE

Original Pinion Gear Depth Variance	Replacement Pinion Gear Depth Variance									
	-4	-3	-2	-1	0	+1	+2	+3	+4	
+4	+0.20	+0.18	+0.15	+0.13	+0.10	+0.08	+0.05	+0.03	0	
+3	+0.18	+0.15	+0.13	+0.10	+0.08	+0.05	+0.03	0	-0.03	

Original Pinion Gear Depth Variance	Replacement Pinion Gear Depth Variance								
	-4	-3	-2	-1	0	+1	+2	+3	+4
+2	+0.15	+0.13	+0.10	+0.08	+0.05	+0.03	0	-0.03	-0.05
+1	+0.13	+0.10	+0.08	+0.05	+0.03	0	-0.03	-0.05	-0.08
0	+0.10	+0.08	+0.05	+0.03	0	-0.03	-0.05	-0.08	-0.10
-1	+0.08	+0.05	+0.03	0	-0.03	-0.05	-0.08	-0.10	-0.13
-2	+0.05	+0.03	0	-0.03	-0.05	-0.08	-0.10	-0.13	-0.15
-3	+0.03	0	-0.03	-0.05	-0.08	-0.10	-0.13	-0.15	-0.18
-4	0	-0.03	-0.05	-0.08	-0.10	-0.13	-0.15	-0.18	-0.20

PINION DEPTH MEASUREMENT

Measurements are taken with the pinion bearing cups and pinion bearings installed in the housing. Take measurements with a Dial Indicator. C-3339A (1).

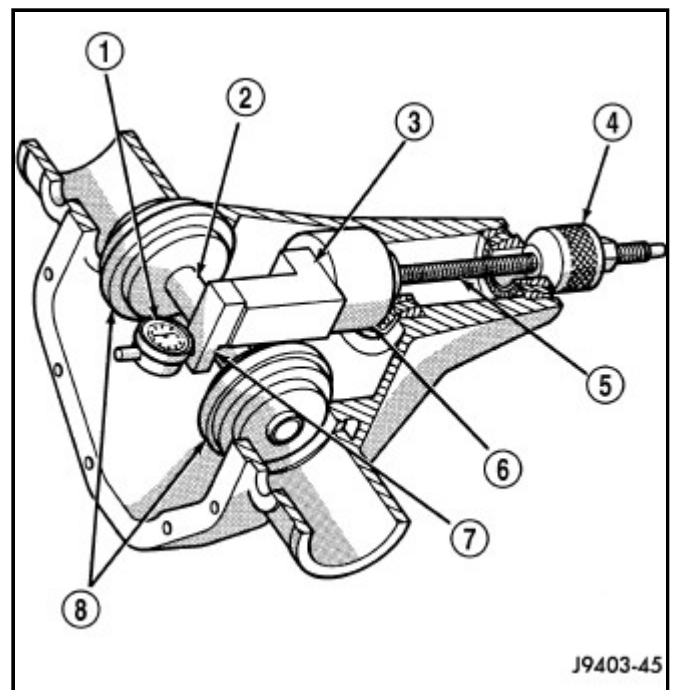

1. Assemble the Pinion Height Block 6739 the Pinion Block Gauge, Pinion Height 38.800 mm 2053200030 for 3.73 and 4.10 axle ratios, or Gauge, Pinion Height 24.800 mm 2053300030 for 3.45 axle ratio (1), and rear pinion bearing onto Screw 6741 .

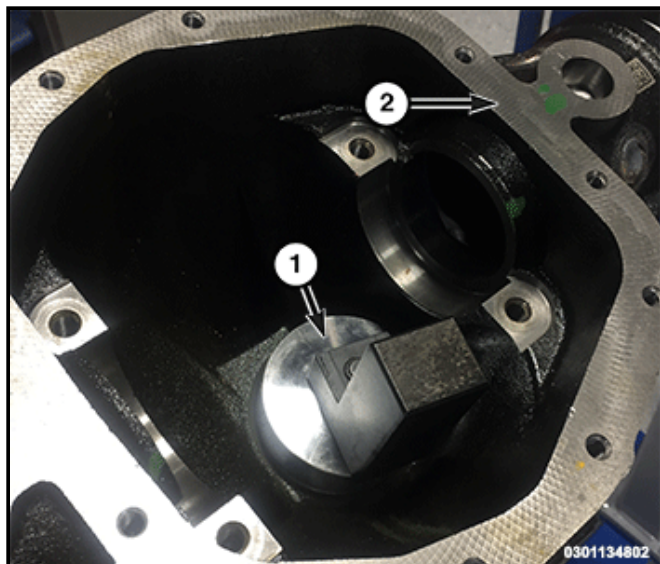

2. Insert assembled height gauge components into the housing (2) through the pinion bearing cups.
3. Install front pinion bearing and Cone-nut 6740 (3). Tighten nut until torque to rotate the screw is 2.25 N·m (20 in. lbs.).

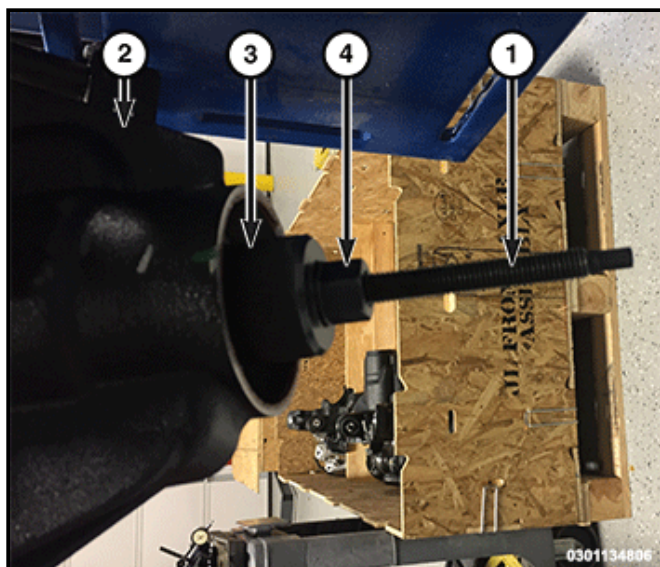

4. Place the Arbor Discs Set, Arbor Disc 2052800030 (2) on the Arbor D-115-3 (1) and position the assembly in the axle housing differential bearing cradles (3).

NOTE:

Arbor Discs Set, Arbor Disc 2052800030 have different step diameters to fit other axles. Choose the proper step for the axle being serviced.

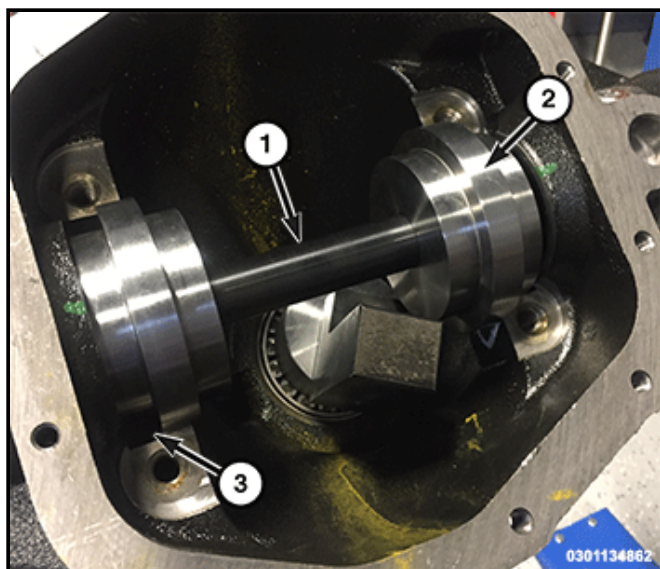

5. Install differential bearing caps (3) on arbor discs (2) and tighten cap bolts (4) to the proper (Torque Specifications) .

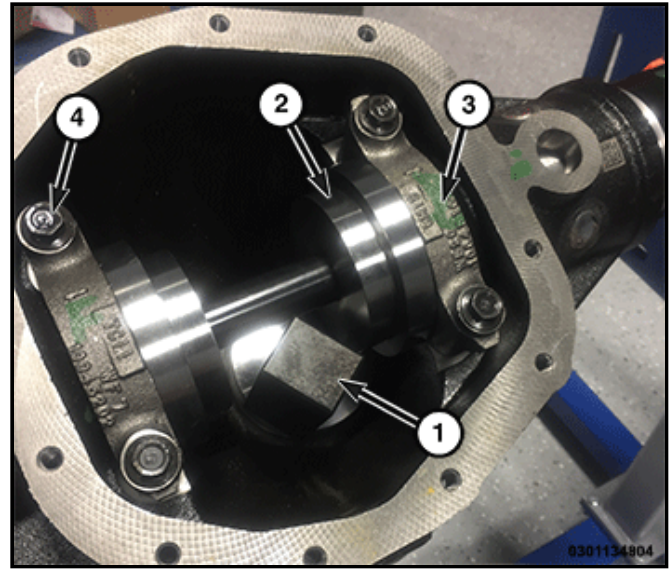

6. Install Dial Indicator C-3339A (3) into Scooter Block D-115-2A (1) and secure set screw.

7. Position Scooter Block/Dial Indicator (3) flush on the pinion height block (1) and zero the dial indicator (3).

8. Slowly slide the scooter block (1) across the pinion height block over to the arbor. Move the scooter block (1) until the dial indicator (3) probe crests the arbor and record the highest reading.

9. Select a washer equal to the dial indicator reading plus or minus the pinion depth variance number etched in the face of the pinion. **Example:** If depth variance is -2 add 0.002 in. to the dial indicator reading. If depth variance is +2 subtract 0.002 in. from the dial indicator reading. The total is the washer thickness needed for the pinion depth variance.

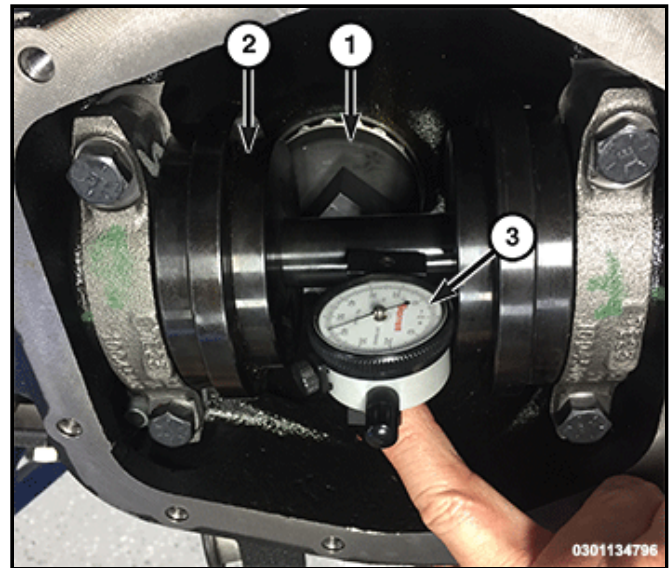

PRELOAD WASHER SELECTION

1. Remove the differential bearing cap bolts (1). If equipped, make note of the orientation of the axle locker actuator bracket (3) and remove the differential bearing caps (2).
2. Remove the factory installed washers from the differential case.
3. Install the Dummy Bearings [Bearing, Dummy 80.000 mm 2052900030](#) and [Bearing, Dummy 77.788 mm 2053000030](#) on the differential case and install the differential case in the axle housing.

4. Install the differential bearing caps (2) in the original location and snug the bearing cap bolts (1).
5. Seat the differential dummy bearings to the pinion gear side of the housing with a dead-blow hammer.
6. Seat the differential dummy bearings to the ring gear side of the housing with a dead-blow hammer.

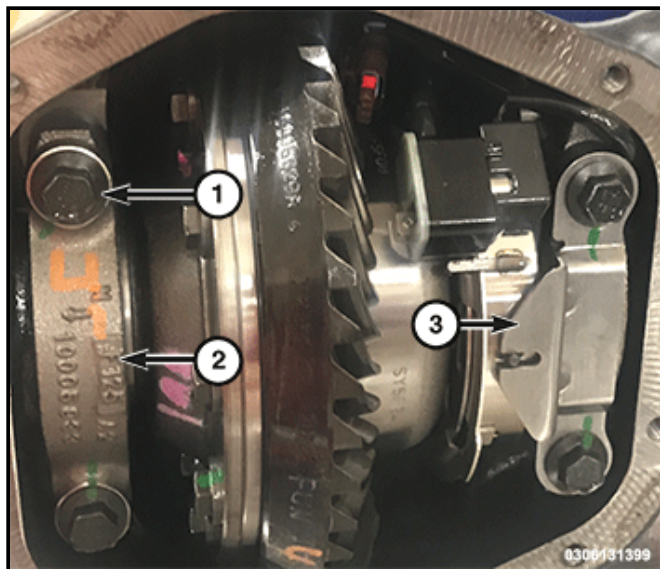

7. Install the C-3288-B (1) in the cover bolt hole.
8. Attach the C-3339A (2) to the pin and position indicator dial indicator (3) plunger on a flat surface between the ring gear bolts (4).

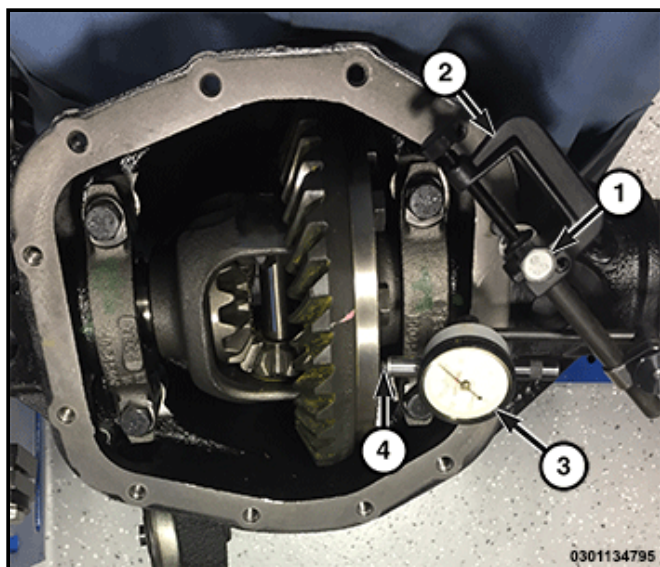

9. Push and hold the differential case (4) to pinion gear side of the housing and zero the dial indicator (3).
10. Push and hold the differential case (4) to the ring gear side of the differential housing. Record the dial indicator (3) reading. Add the preload specification 0.05 mm (0.002 in.) to the differential dial indicator reading. This is the total differential washer thickness needed to preload the differential bearings. **EXAMPLE:** Differential Dial Indication Reading + Preload Specification 0.05 mm (0.002 in.) = Total Differential Washer.
11. Rotate the dial indicator (3) out of the way on the pilot stud.
12. Remove the differential case (4) and dummy bearings from the differential housing.

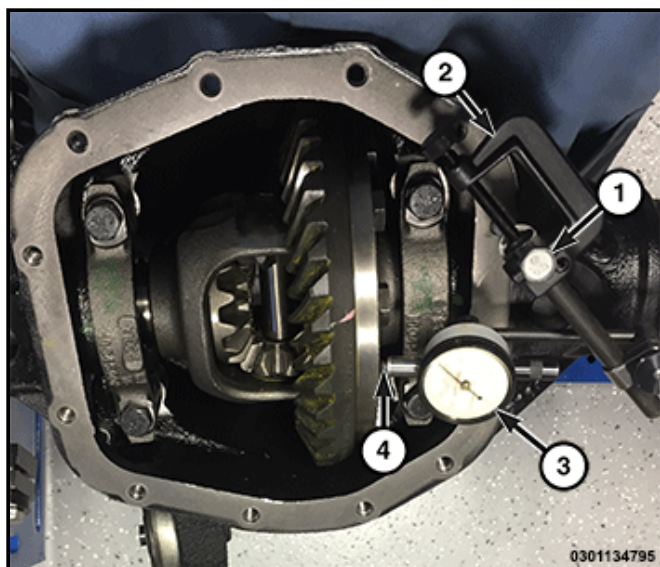

13. Install the pinion gear in the axle housing and establish the pinion torque to rotating (PTTR).

14. Install the differential case (4) with the Dummy Bearings Bearing, Dummy 80.000 mm 2052900030 and Bearing, Dummy 77.788 mm 2053000030 in the axle housing, install the bearing caps and snug the bolts.

15. Seat the ring gear side dummy bearing.

16. Position the dial indicator (3) plunger on a flat surface between the ring gear bolts.

17. Push and hold the differential case (4) against the pinion gear and zero the dial indicator (3).

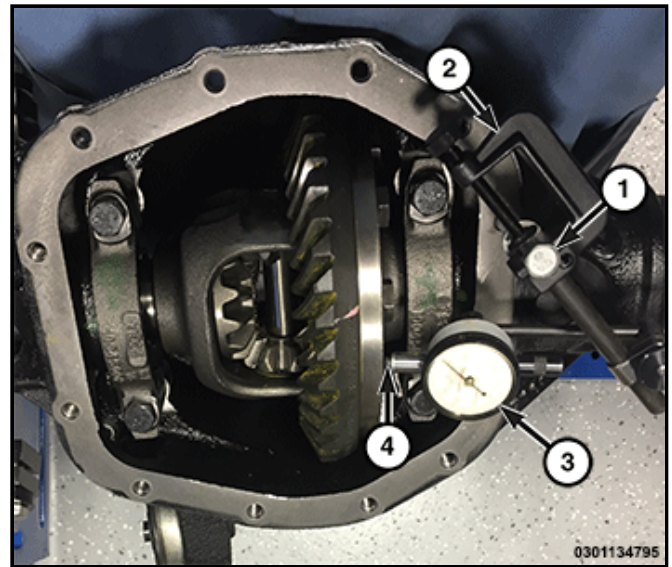

18. Push and hold the differential case (4) to the ring gear side of the axle housing and record the dial indicator (3) ring gear side reading.

19. Subtract the backlash specification 0.16 mm (0.006 in.) from the ring gear side reading for the ring gear backlash. The remainder is the washer needed on the ring gear side of the differential. **EXAMPLE:** Ring Gear Side Reading - Backlash Specification 0.16 mm (0.006 in.) = Ring Gear Side Washer.

20. Subtract the ring gear side washer from the differential total preload washer. The remainder is the washer needed on the pinion gear side of the differential. **EXAMPLE:** Total Differential Washer - Ring Gear Side Washer = Pinion Gear Side Washer.

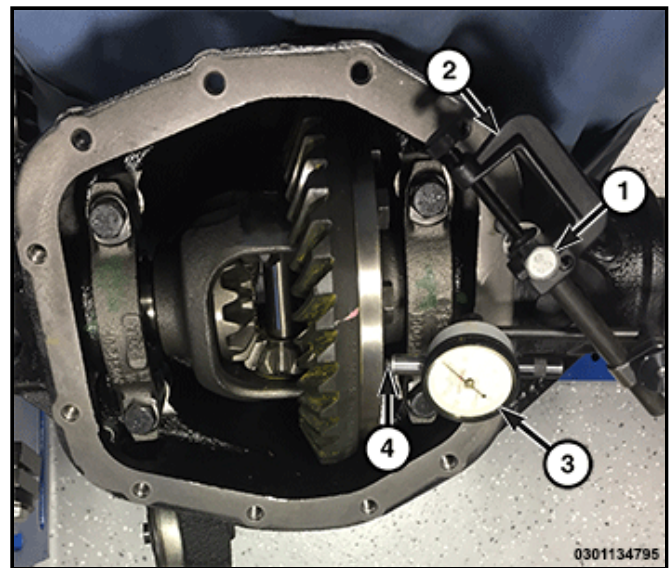

21. Rotate the dial indicator (3) out of the way on the pilot stud.

22. Remove the differential case (4) with dummy bearings from the differential housing (Refer to 03 - Differential and Driveline/Front Axle/CASE ASSEMBLY, Differential, Removal and Installation) .

23. Install the differential side bearings on the differential case (Refer to 03 - Differential and Driveline/Front Axle/BEARING, Differential Side/Removal and Installation) .

24. Install the W-129-B (1) and 6987B (2), on the axle housing. Spread the housing 0.50 mm (0.020 in.).

CAUTION:

Never spread housing over 0.50 mm (0.020 in.). Failure to follow these instruction could result in distorting the housing.

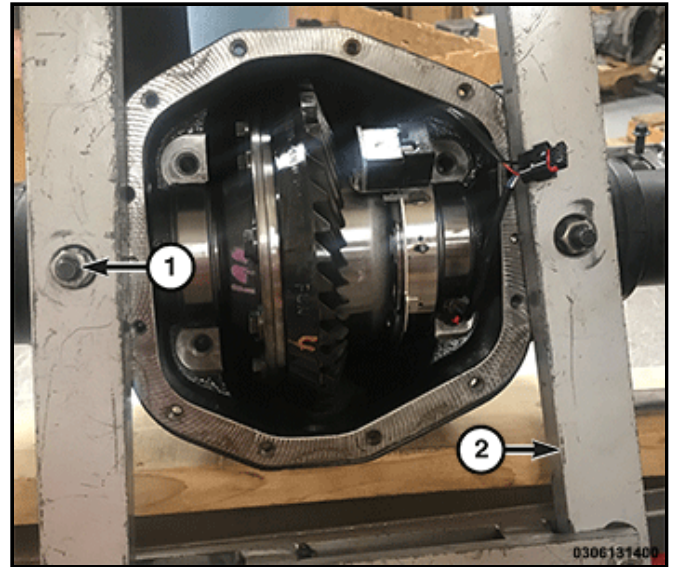

25. Install the differential case (1) with the differential bearings cups (3) and washers in the differential housing (2).

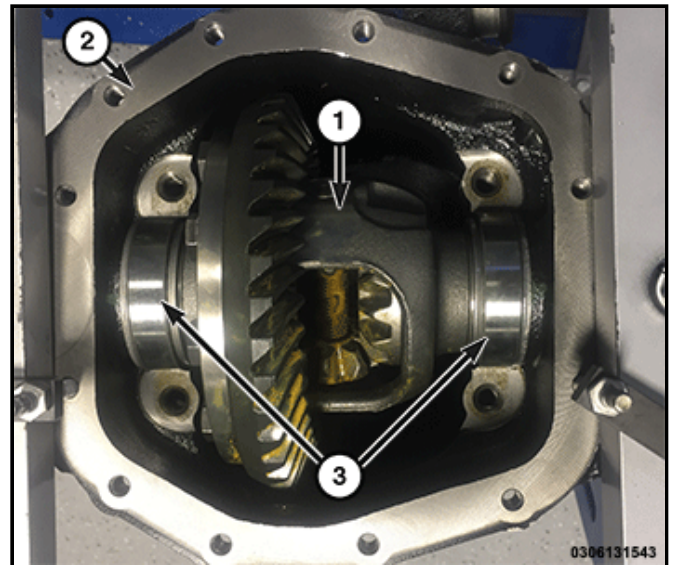

26. Remove the spreader from the differential housing.
27. Install the differential bearing caps (1, 2) and tighten the differential bearing cap bolts to the proper ([Torque Specifications](#)) .
28. Rotate the differential case several times to seat the differential side bearings.

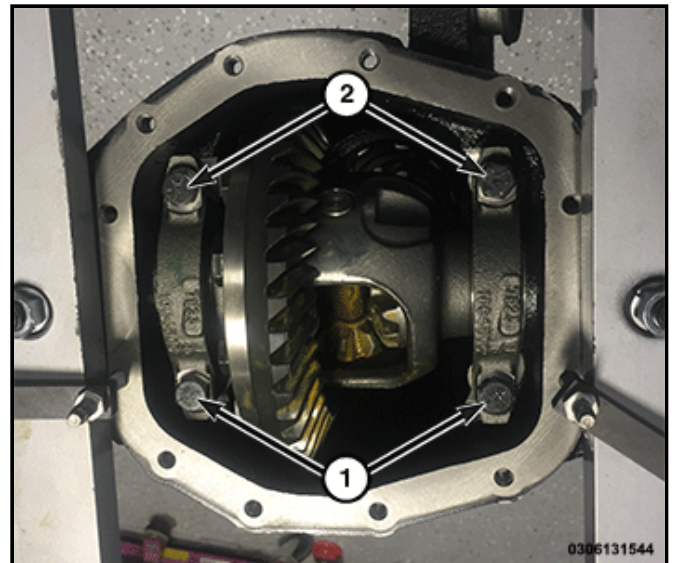

29. Position the dial indicator plunger (1) against a ring gear tooth.
30. Push and hold the ring gear upward while holding the pinion gear.
31. Zero the dial indicator face to pointer.

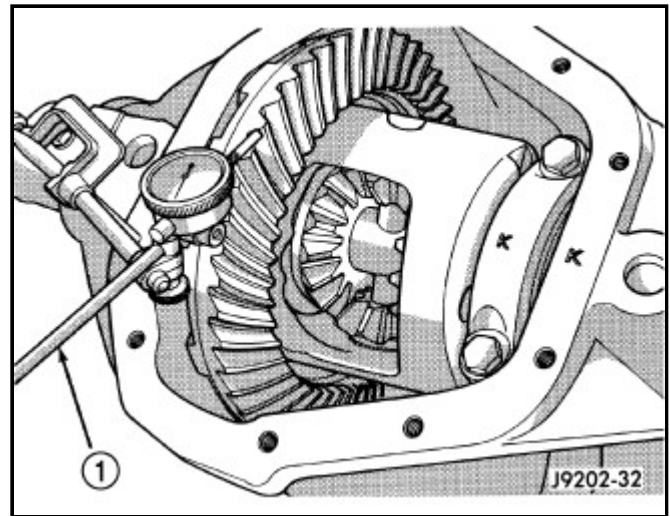

32. Push and hold the ring gear downward while holding the pinion gear. The dial indicator reading should be between 0.12 mm - 0.20 mm (0.005 in - 0.008 in). If the backlash is not within specifications transfer the necessary amount of shim thickness from one side of the axle housing to the other.
33. Verify the differential case and ring gear run-out by measuring ring to pinion gear backlash at eight locations around the ring gear. Readings should not vary more than 0.05 mm (0.002 in.). If the readings vary more than specified, the ring gear or the differential case is defective.

After the proper backlash is achieved, perform Gear Contact Pattern procedure.

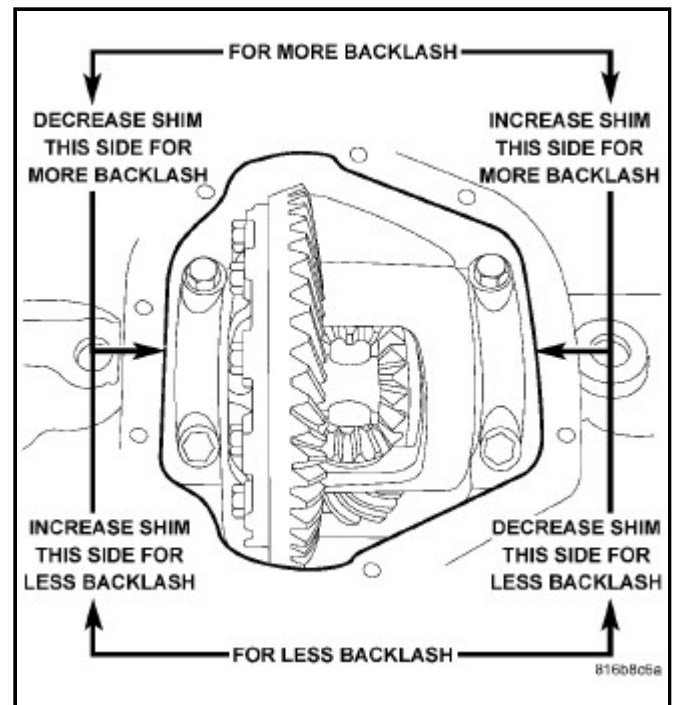

GEAR CONTACT PATTERN

The ring gear and pinion teeth contact patterns will show if the pinion depth is correct in the housing. It will also show if the ring gear backlash has been adjusted correctly. The backlash can be adjusted within specifications to achieve desired tooth contact patterns.

The top land(1) of the gear tooth is the top surface of the tooth. The profile (2) of the gear tooth is the depth of the tooth. The toe (3) of the gear is the portion of the tooth surface at the end towards the center. The heel (4) of the gear is the portion of the tooth at the outer-end. The root (5) of the gear tooth is the lowest portion of the tooth.

NOTE:

If the profile across the tooth is the same it is a three axis cut gear. If the profile across the tooth is tapered it is a two axis cut gear.

1. Apply a thin coat of hydrated ferric oxide or equivalent to the drive and coast side of the ring gear teeth.
2. Wrap, twist and hold a shop towel around the pinion yoke to increase the turning resistance of the pinion. This will provide a more distinct contact pattern.
3. With a boxed end wrench on the ring gear bolt, rotate the differential case one complete revolution in both directions while a load is being applied from shop towel.

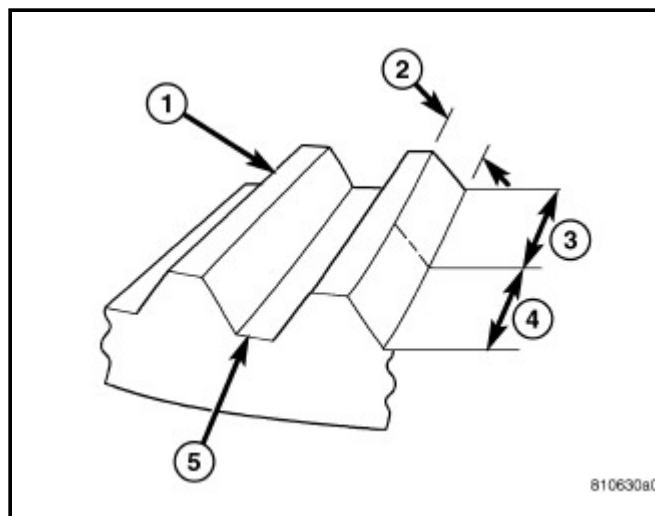

The areas on the ring gear teeth with the greatest degree of contact against the pinion teeth will squeegee the compound to the areas with the least amount of contact. Note and compare patterns on the ring gear teeth to Gear Tooth Contact Patterns chart adjust pinion depth and gear backlash as necessary.

DRIVE SIDE HEEL TOE	CONDITION	COAST SIDE TOE HEEL	CONDITION	ACTION REQUIRED
	Desirable pattern. The drive pattern should be centered on the tooth. There should be some clearance between the pattern and the top of the tooth.		Desirable pattern. The coast pattern should be centered on the tooth, but may be slightly toward the toe. There should be some clearance between the pattern and the top of the tooth.	None
	Top toe contact		Top heel contact	Backlash correct. Thicker pinion position shim required.
	Root heel contact		Root toe contact	Backlash correct. Thinner pinion position shim required.
	Top heel contact		Top toe contact	Pinion position shim correct. Decrease backlash.
	Root toe contact		Root heel contact	Pinion position shim correct. Increase backlash.

8106361d

DIFFERENTIAL BEARING PRELOAD CHECK

The final check on the differential assembly before installing the axle shafts is, torque to rotate pinion, and differential combined. This will verify the correct differential bearing preload.

Total Torque To Rotate (TTTR) is: Pinion Torque To Rotate plus 0.45 - 0.95 N·m (4 - 8 in. lbs.).

NOTE: If TTTR is high, decrease the washer thickness equally on both sides of the differential and check TTTR again. If TTTR is low, increase the washer thickness equally on both sides of the differential and check TTTR again.