

## **DESCRIPTION AND OPERATION**

### **DESCRIPTION**

Tru-Lok is an electronically locking differential. The differential has four pinion gears, three pinion shafts and two side gears. On the back side of one side gear is half of the dog clutch.

**NOTE:** The actuator is a serviceable component.

### **OPERATION**

Pressing a two-way momentary rocker switch on the switch bank request axle lock. The first press DOWN requests rear axle to be locked, every other press DOWN toggles between "front and rear axle lock" and "rear axle lock" request states. Press rocker switch UP requests both axles to be unlocked. The switch is on the IP in the switch bank. The switch bank sends a message to the Instrument Panel Cluster (IPC). The IPC handles the switch debounce and switch diagnostics. Any one message sent by the IPC on the network is a valid switch change. The IPC passes the information via a Controller Area Network-Internal High Speed (CAN-IHS) message. There are three telltales on the cluster, "Rear", "Front", and "Lock". The telltales will be off if the axles are unlocked, flashing if there is a pending request to lock but the axles are not yet locked (transition to lock, torque-locked, or conditions not correct), and flashing rapidly if there is a fault. The "Front" and "Rear" telltales will match the front and rear differential states. The "Lock" telltale will be on solid if either the "Front" or "Rear" telltale is on or blinking. For more information on locker operation (Refer to 08 - Electrical/8E - Electronic Control Modules/MODULE, Drivetrain Control/Description and Operation).

## **DIAGNOSIS AND TESTING - DIFFERENTIAL - TRU-LOK**

The electronic control module for the electronically locking differentials detects faults from input signal/messages, sensors, solenoids, and drivers/relays and report the corresponding Diagnostic Trouble Code (DTC).

The following description outlines the lighting strategy for the axle lock switch:

The FRONT AXLE LED will:

- Turn ON SOLID when the front axle is locked
- Turn ON BLINKING when the front axle is attempting to lock
- Turn ON BLINKING when a lock front axle request is received but conditions to lock are not correct
- Turn OFF when the axle is UNLOCKED
- Turn ON FAST BLINKING when there is a fault detected for the front axle

The REAR AXLE LED will:

- Turn ON SOLID when the rear axle is locked
- Turn ON BLINKING when the rear axle is attempting to lock
- Turn ON BLINKING when a lock rear axle request is received but conditions to lock are not correct
- Turn OFF when the axle is UNLOCKED
- Turn ON FAST BLINKING when there is a fault detected for the rear axle

### **INDICATOR SWITCH**

Ohmmeter set on continuity: One lead on each connector terminal

- Switch Plunger IN Locker Not Engaged - No Continuity
- Switch Plunger OUT Locker Engaged - Continuity

## 03 - Differential and Driveline/Rear Axle - M220/CASE ASSEMBLY, Differential, TRU-LOK/Removal and Installation

### REMOVAL AND INSTALLATION

**+** **Labor Operations:** Click to display a list of Labor Operations associated with this procedure

**-** **Special Tools:** Click to hide the list of tools used in this procedure

[Click here to launch the form to order any tools you need.](#)

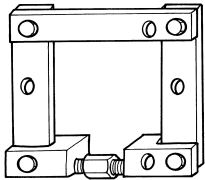
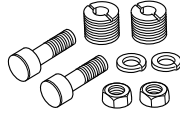
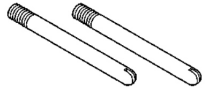
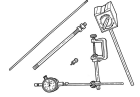
	<p>W-129-B - Spreader, Differential</p> <p>Originally Shipped In Kit Number(s) 9975.</p>
	<p>6987B - Adapter Kit, Axle Spreader</p> <p>Originally Shipped In Kit Number(s) 6980, 6994, 6995, 8653.</p>
	<p>C-3288-B - Set, Alignment Pins</p> <p>Originally Shipped In Kit Number(s) 9975.</p>
	<p>C-3339A - Set, Dial Indicator</p> <p>Originally Shipped In Kit Number(s) 9202.</p>

### REMOVAL

1. Raise and support the vehicle ([Refer to 04 - Vehicle Quick Reference/Hoisting/Standard Procedure](#)) .
2. Remove the differential drain plug and drain the fluid.
3. Remove the differential cover ([Refer to 03 - Differential and Driveline/Rear Axle/COVER, Differential/Removal and Installation](#)) .
4. Remove the axle locker switch ([Refer to 03 - Differential and Driveline/Rear Axle/SWITCH, Axle Lock/Removal and Installation](#)) .
5. Remove the axle shafts ([Refer to 03 - Differential and Driveline/Rear Axle/SHAFT, Axle/Removal and Installation](#)) .
6. Remove the axle locker switch ([Refer to 03 - Differential and Driveline/Rear Axle/SWITCH, Axle Lock/Removal and Installation](#)) .
7. Loosen the differential bearing cap bolts (1, 2).

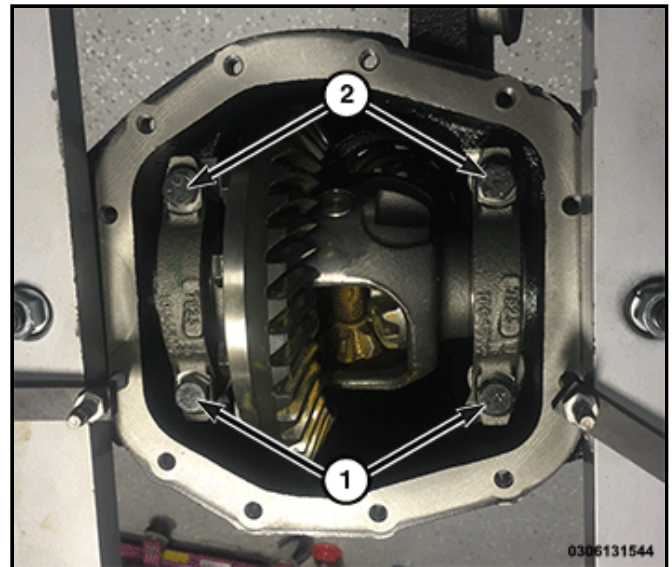

0306131544

8. Position the [W-129-B](#) (1) with [6987B](#) on the differential housing locating holes. Install the hold-down clamps and tighten the turnbuckle finger-tight.
9. Install an [C-3288-B](#) (4) on the left side of the differential housing. Attach the [C-3339A](#) (2) to the pin. Load the dial indicator plunger against the opposite side of the differential housing spreader (3) and zero the dial indicator.
10. Spread differential housing while measuring the distance with the dial indicator.

**NOTE:** Never spread the differential housing over 0.64 mm (0.025 in.). Failure to follow these instructions will damage the housing.

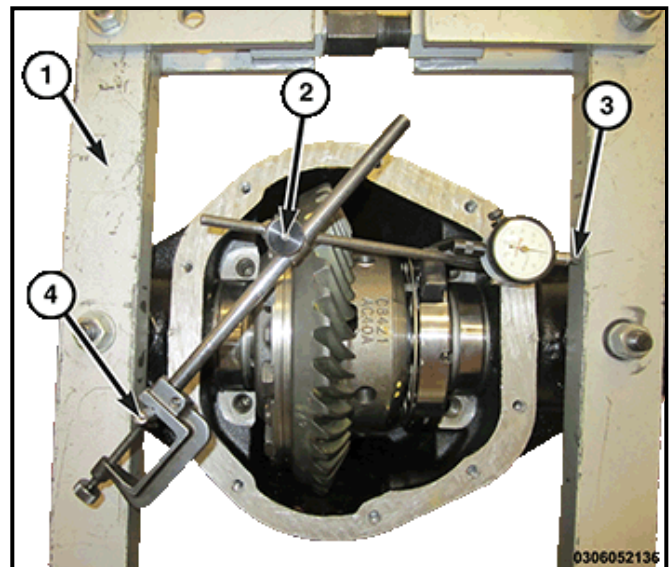

0306052136

11. Remove the dial indicator.
12. Holding the differential case in position, remove the differential bearing cap bolts (1, 2).

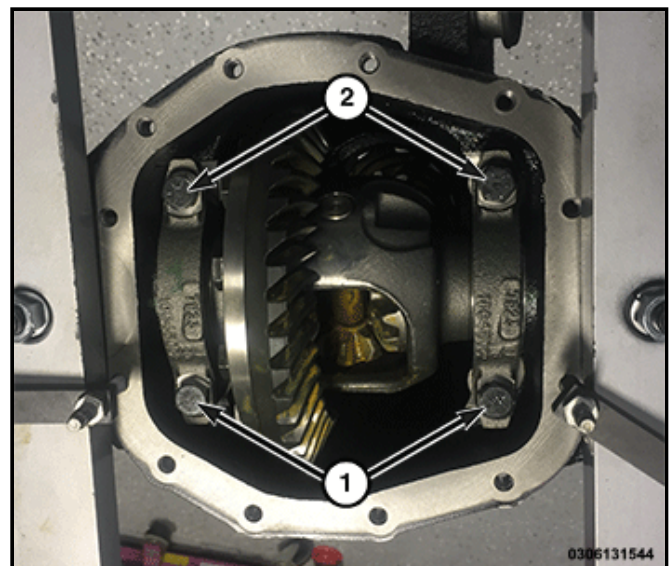

0306131544

13. Remove the coil anti-rotation bracket (3) from the bearing cap, remove both bearing caps (2).

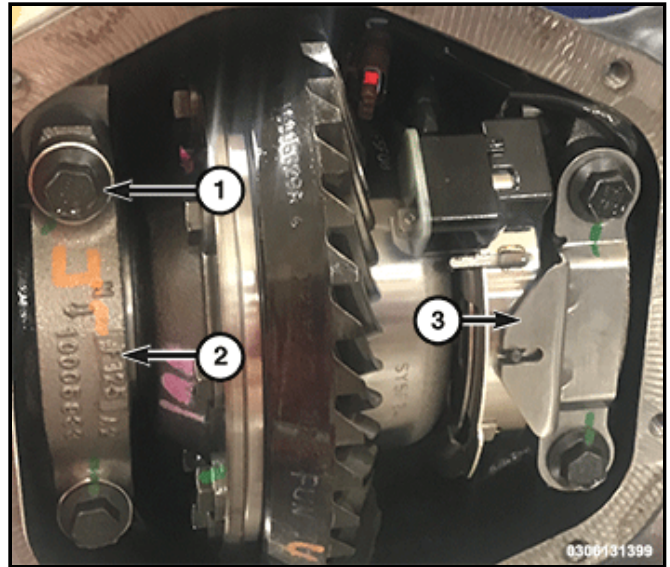

14. Remove the differential case (1) from the differential housing (2) and tag the differential bearing cup and washer (3) locations.

**NOTE:** Non-locker rear differential case assembly shown for bearing clarity.

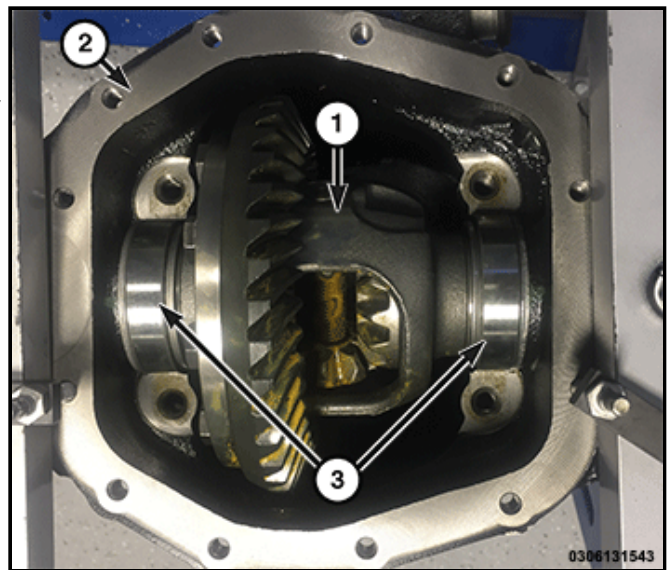

15. Remove the W-129-B (1) and 6987B (2) from the housing.

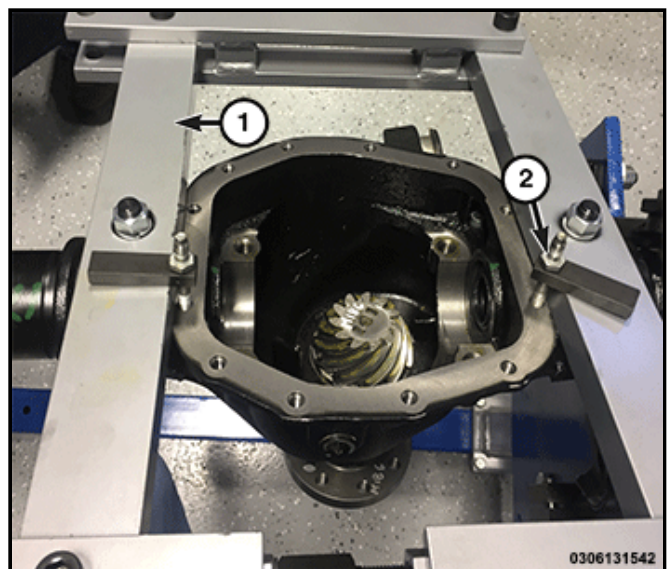

**NOTE:** Do not use water, steam, kerosene or gasoline for cleaning.

- Clean the differential housing cavity with flushing oil, light engine oil or lint free cloth.

## INSTALLATION

### NOTE:

If replacement differential bearings or a differential case are being installed, the differential side bearing washer requirements may change. Refer to Adjustments (Differential Bearing Preload and Gear Backlash) to determine the proper washer selection.

- Position the W-129-B (1) and 6987B seated in the differential housing locating holes. Install the hold-down clamps (2) and tighten the turnbuckle finger-tight.

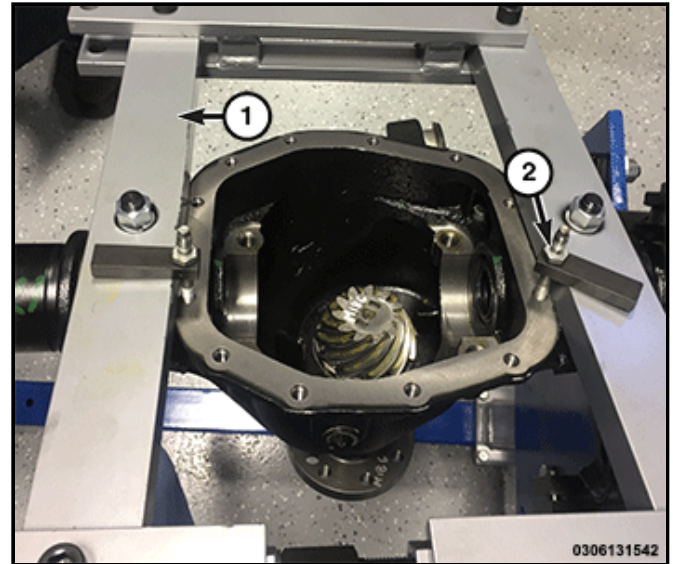

- Install an C-3288-B at the left side of the axle housing. Attach the C-3339A (1) to the pin. Load the indicator plunger (2) against the opposite side of the differential housing and zero the dial indicator.

**NOTE:** Never spread the differential housing over 0.64 mm (0.025 in.). Failure to follow these instructions will damage the housing.

- Spread the differential housing while measuring the distance with the dial indicator.
- Remove the dial indicator.

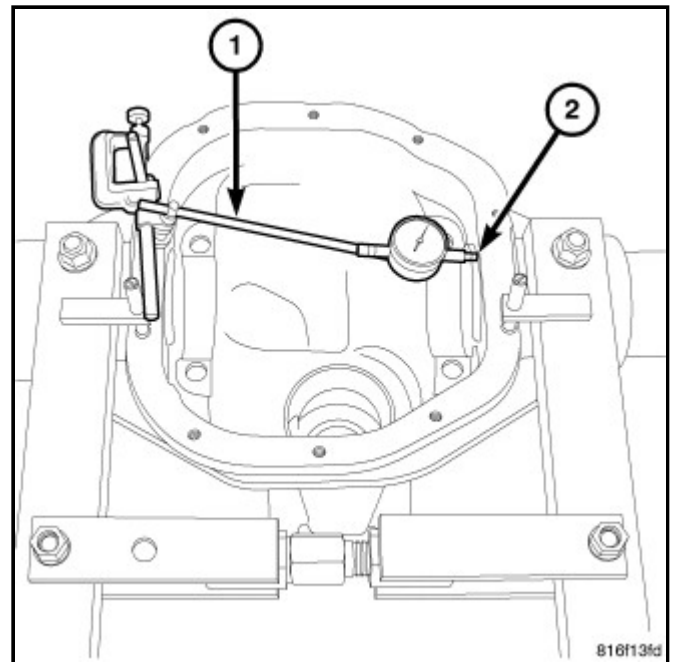

- Install the differential case (1) into the differential housing (2) with the differential bearing cups and washers (3) in their original locations.

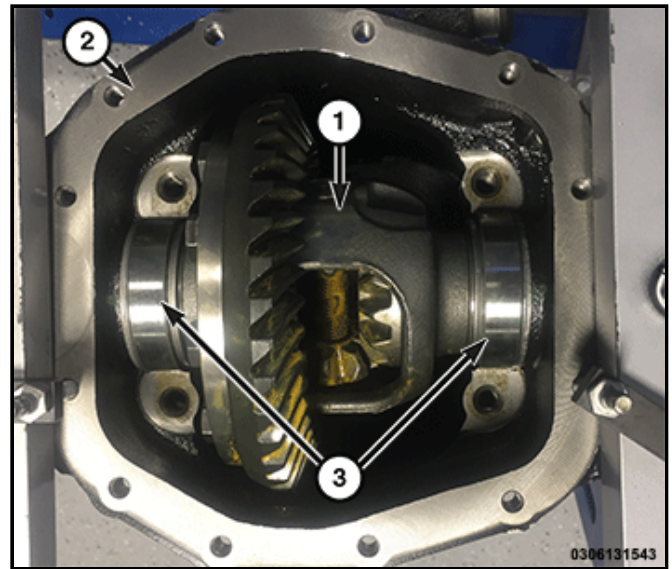

**NOTE:** Non-locker rear differential case assembly shown for bearing clarity.

6. Install the bearing caps (2) in their original locations and install and center the coil anti-rotation bracket (3).

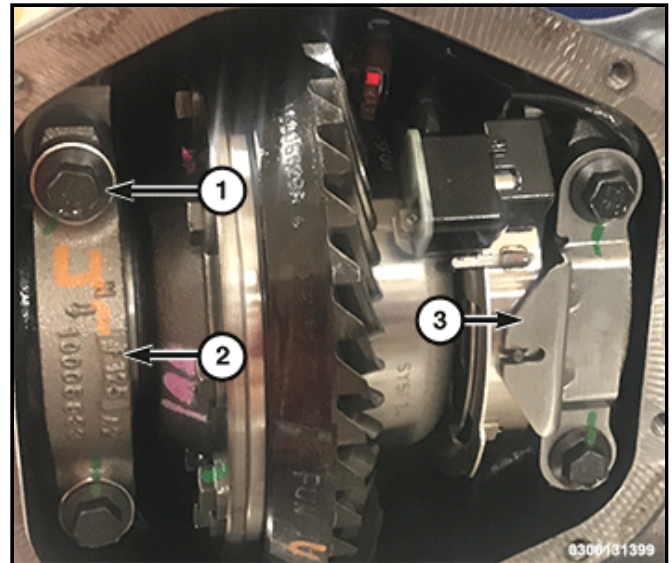

7. Loosely install the differential bearing cap bolts (1, 2).
8. Remove the differential housing spreader.
9. Tighten the bearing cap bolts (1, 2) in a criss-cross pattern to the proper (Torque Specifications) .

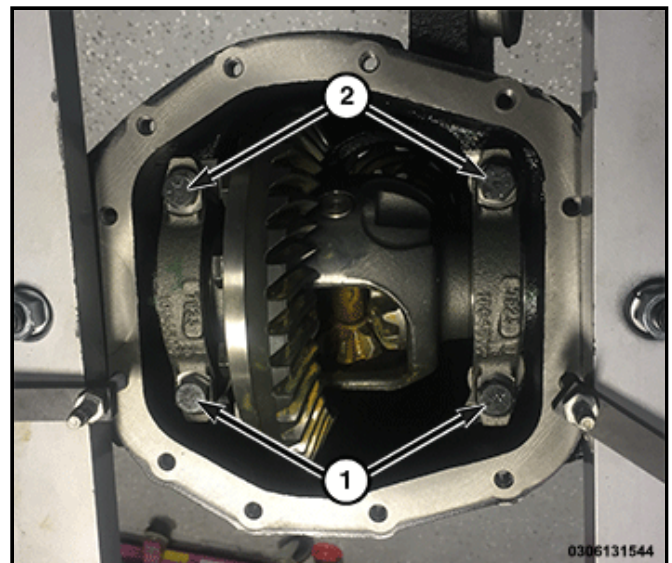

10. Install the axle shafts (Refer to 03 - Differential and Driveline/Rear Axle/SHAFT, Axle/Removal and Installation) .
11. Install the axle locker switch (Refer to 03 - Differential and Driveline/Rear Axle/SWITCH, Axle Lock/Removal and Installation) .
12. Install the differential cover (Refer to 03 - Differential and Driveline/Rear Axle/COVER, Differential/Removal and Installation) .
13. Fill the differential with the specified fluid (Refer to 04 - Vehicle Quick Reference/Capacities and Recommended Fluids/Specifications) .
14. Remove the support and lower the vehicle.

## 03 - Differential and Driveline/Rear Axle - M220/CASE ASSEMBLY, Differential, TRU-LOK/Disassembly and Assembly

### DISASSEMBLY AND ASSEMBLY

**Labor Operations:** Click to hide the list of LOPs associated with this procedure

No LOP information available for this service procedure.

**Special Tools:** Click to hide the list of tools used in this procedure

[Click here to launch the form to order any tools you need.](#)

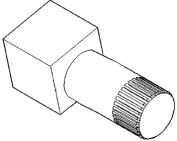
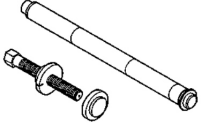
	<p>6963B - Fixture, Holding</p> <p>Originally Shipped In Kit Number(s) 6945, 6947, 6949.</p>
	<p>C-4487 - Trac-Lok Axle Tool</p> <p>Originally Shipped In Kit Number(s) 8667.</p>

### DISASSEMBLY

1. Remove the ring gear (Refer to 03 - Differential and Driveline/Rear Axle/GEAR, Ring and Pinion/Removal and Installation) .
2. Clamp the 6963B in a vise and set the differential case (3) on the fixture.

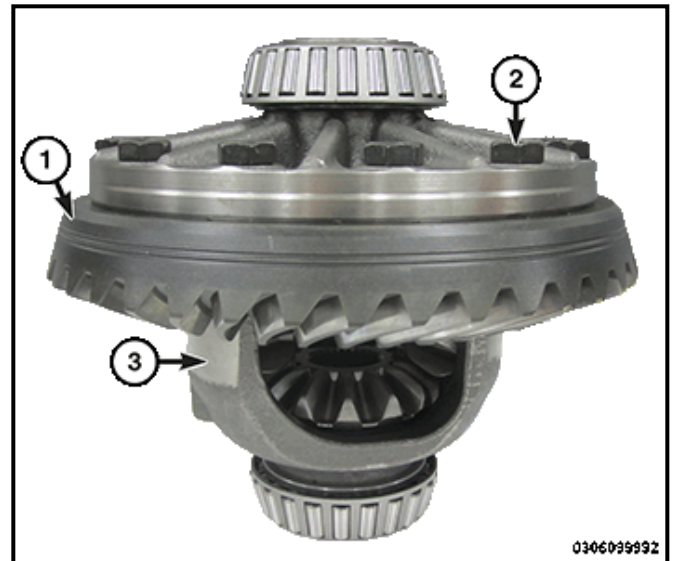

3. Remove the pinion gear mate shaft roll pin (3) from differential case using a suitable punch (2) and hammer (1).

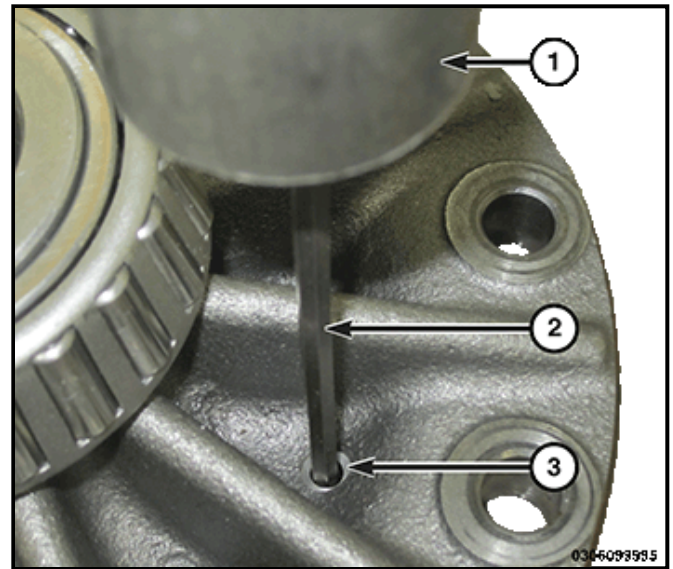

4. Rotate the differential case (1) on the fixture and remove the pinion mate shaft (2).

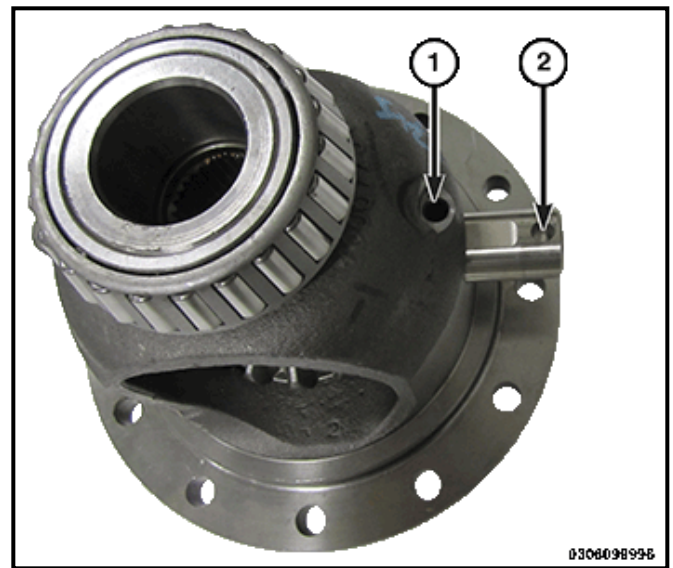

5. Lubricate and install the disc (1) without the threaded hole from the C-4487 into lower side gear (2).

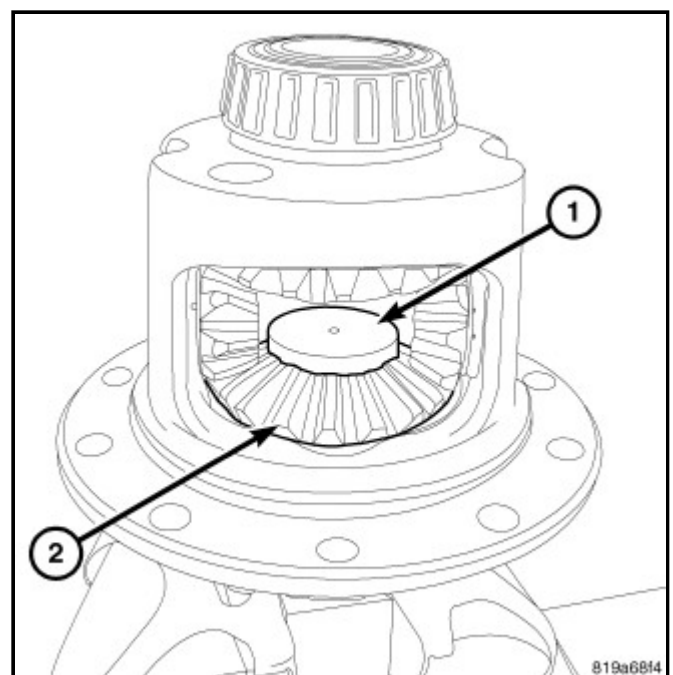

6. Lubricate and install the disc (1) with threaded hole from the C-4487 into upper side gear (2). Thread forcing screw (3) from the C-4487 into upper disc until it contacts the lower disc (4).

**NOTE:**

The slot in the threaded upper disc (1) can be used to prevent it from turning using a screwdriver.

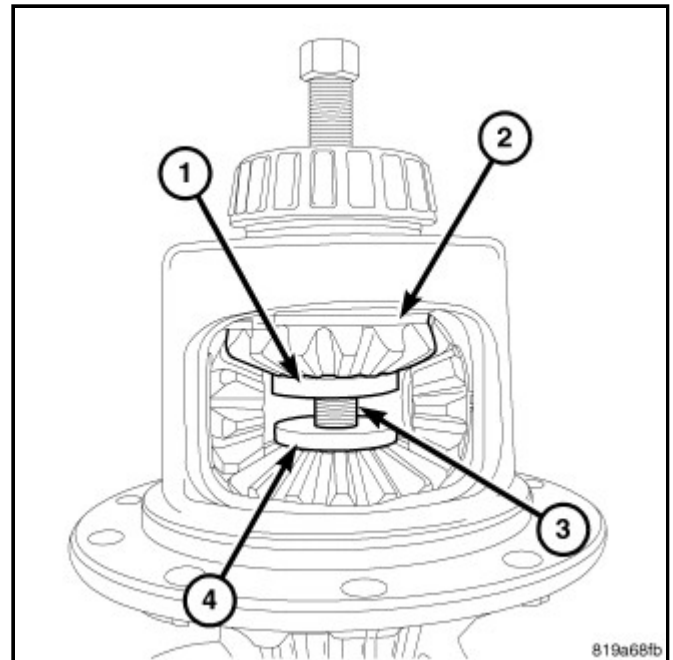

7. Tighten the forcing screw to compress the Belleville springs in the clutch packs. Insert the turning bar (1) from the C-4487 into the pinion mate shaft hole in the case (2).

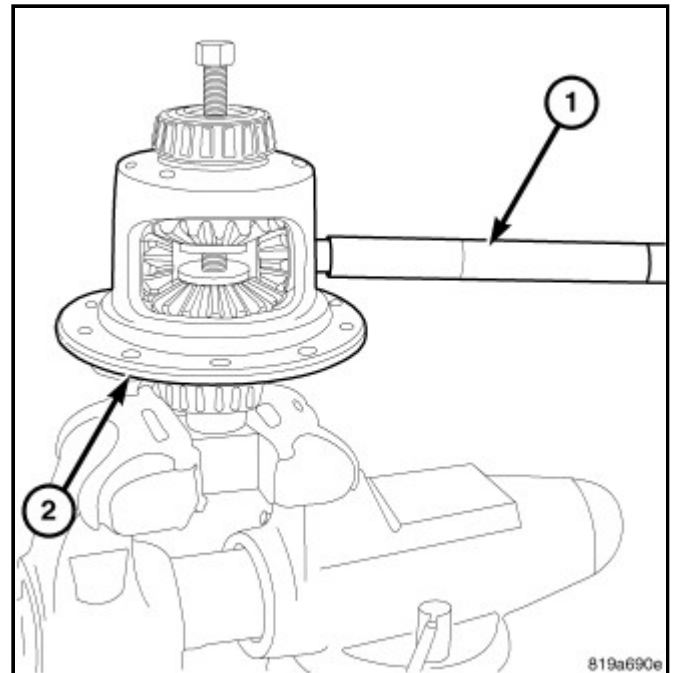

8. Rotate the differential case with the turning bar until the pinion gears (2) and washers can be removed.

**NOTE:**

Loosen the forcing screw in small increments to relieve the clutch pack tension if the differential case can not be rotated.

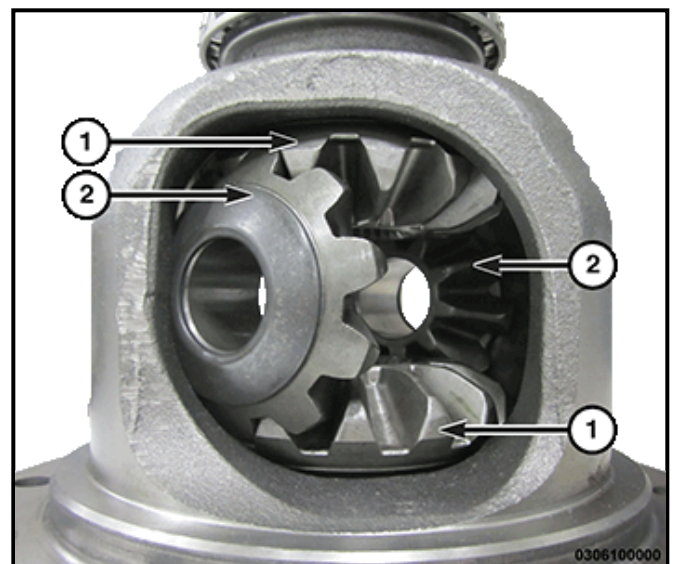

9. Remove the forcing screw, step plate and threaded adapter.
10. Remove the upper clutch pack (1), clutch pack retainers (2) and the upper side gear (3) from the differential case.

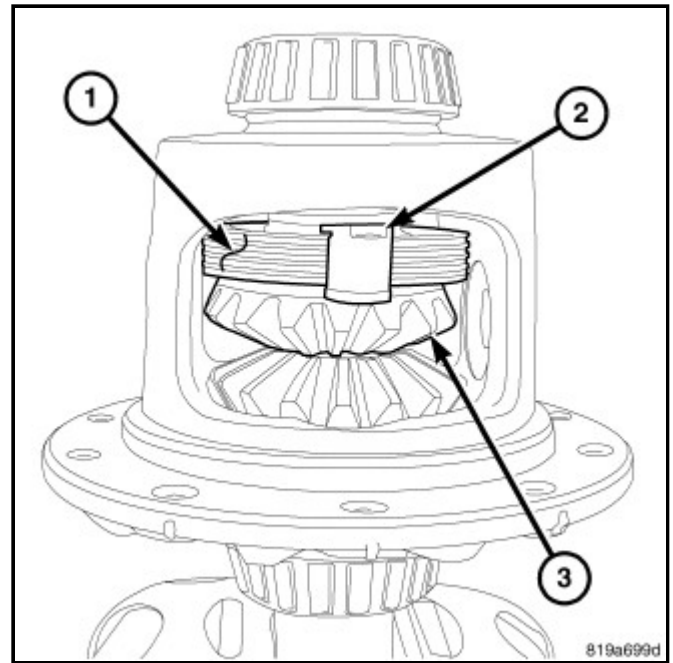

11. Remove the lower clutch pack, clutch pack retainers and lower side gear (1) from the differential case.

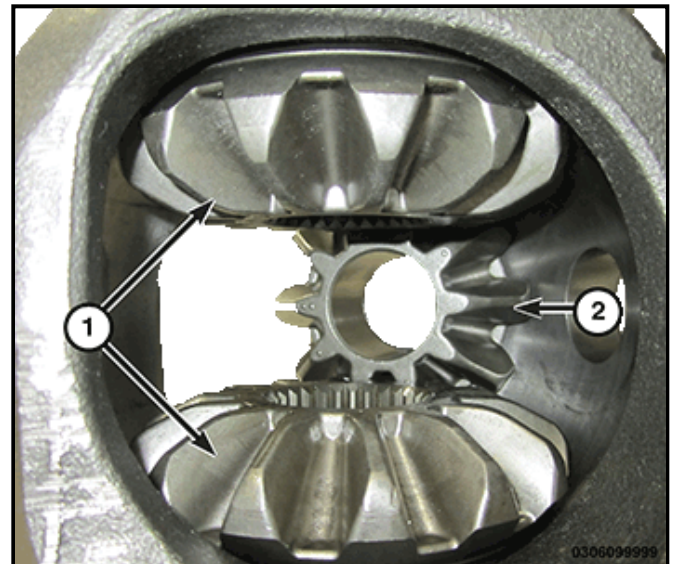

12. Remove the clutch pack retainers (1), clutch pack (3) Belleville spring (2) and the side gear (4). Keep the plates in order during removal.

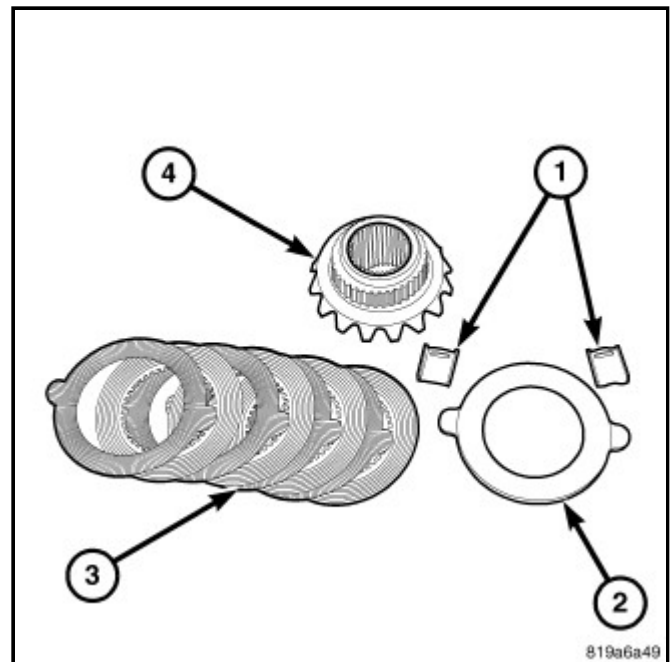

## ASSEMBLY

### NOTE:

New plates and discs with fiber coating (no grooves or lines) must be presoaked in friction modifier before assembly. Soak plates and discs for a minimum of 20 minutes.

1. Lubricate the components with gear lubricant.
2. Assemble the clutch discs (2), plates (6) and Belleville spring (1) into the packs and secure the disc packs with the retainers (5).

### NOTE:

The Belleville spring (1) is positioned with the convex side against the differential case.

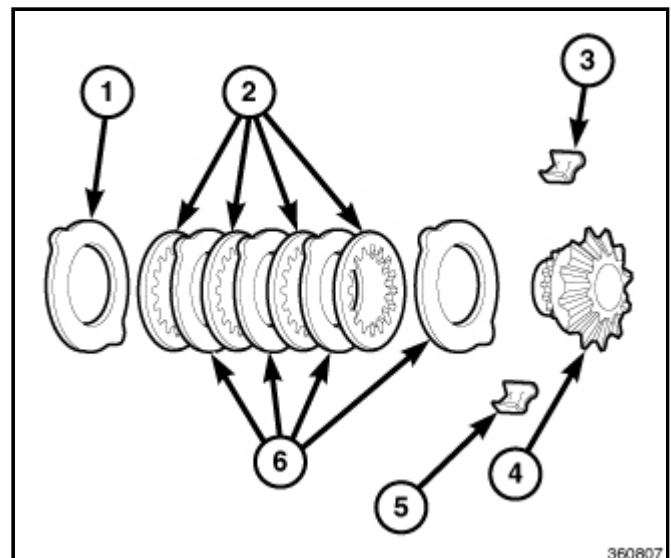

3. Position the assembled clutch disc packs on the side gear (4) hubs.
4. Install the lower clutch pack and side gear (1) in the differential case (2), with the retaining clips seated in the case pocket.

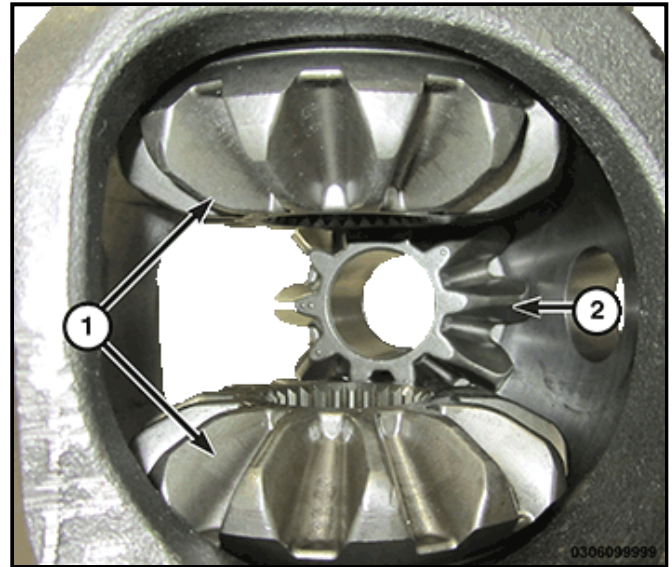

5. Install the upper clutch disc pack (1) retaining clips (2) and the side gear (3) in the differential case pocket.

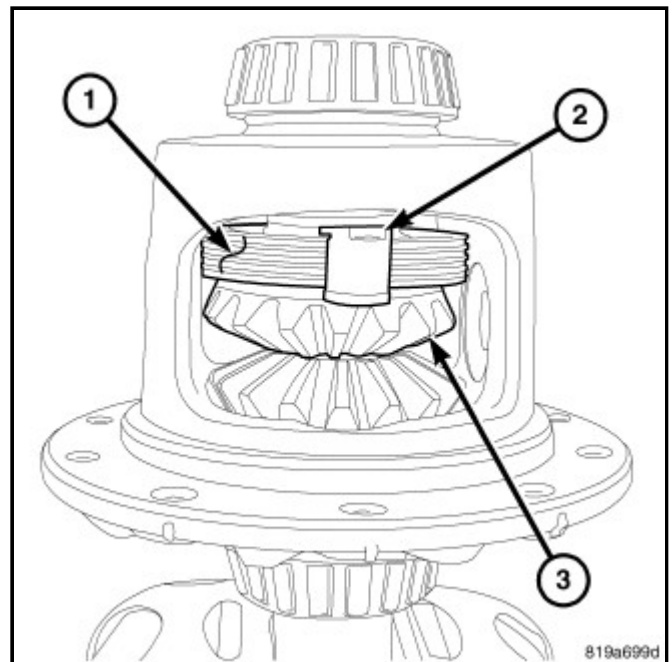

6. Lubricated and install the discs into the side gears (2) from the [C-4487](#) . Install forcing screw from the [C-4487](#) and the threaded screw to compress the Belleville springs in the clutch packs.

7. Install the pinion gears (2) in the side gears opposite of each other.

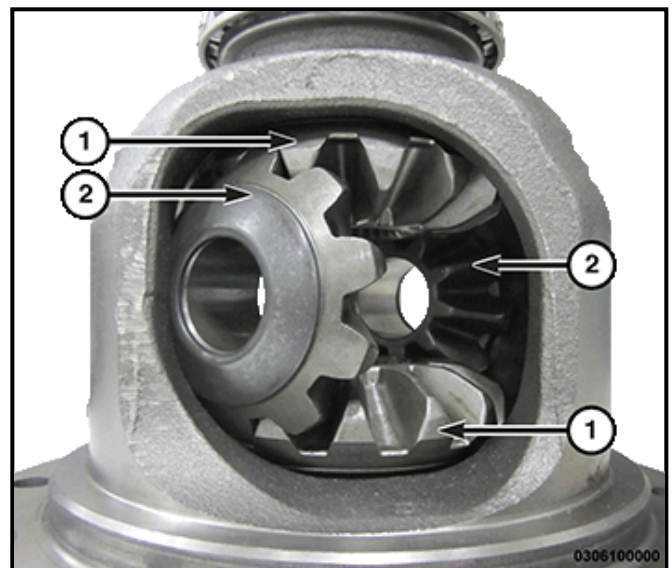

8. Rotate the differential case (2) with the turning bar (1) from the C-4487 until the pinion gears align with the mate shaft holes in the differential case.

**NOTE:**

Loosen the forcing screw in small increments to relieve the clutch pack tension if the differential case can not be rotated.

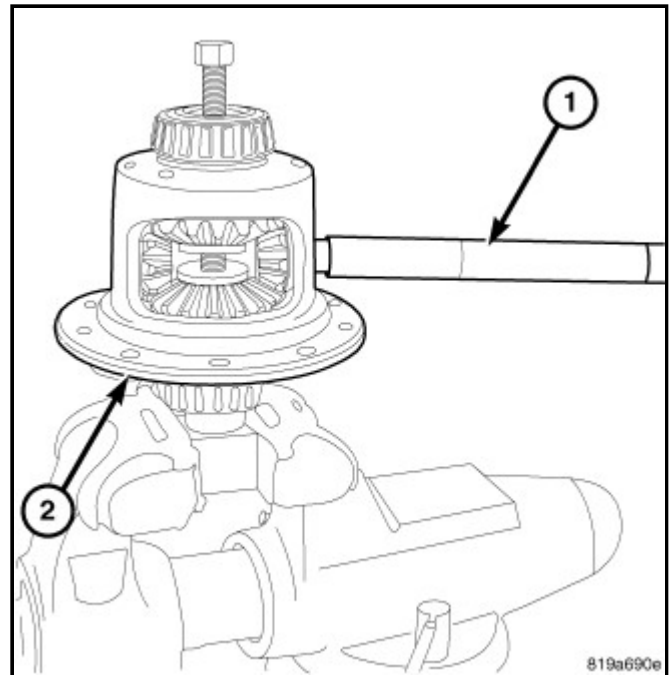

9. Install the pinion gear thrust washers (1) between the gear and the case (2). Align the washers with the mate shaft hole in the case.

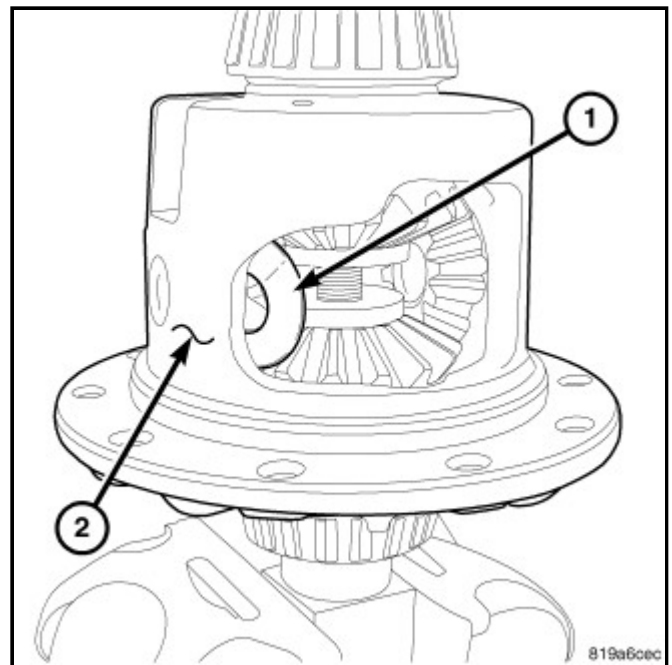

10. Remove the forcing screw upper disc from the side gear.

11. Remove the lower disc from the side gear (2).

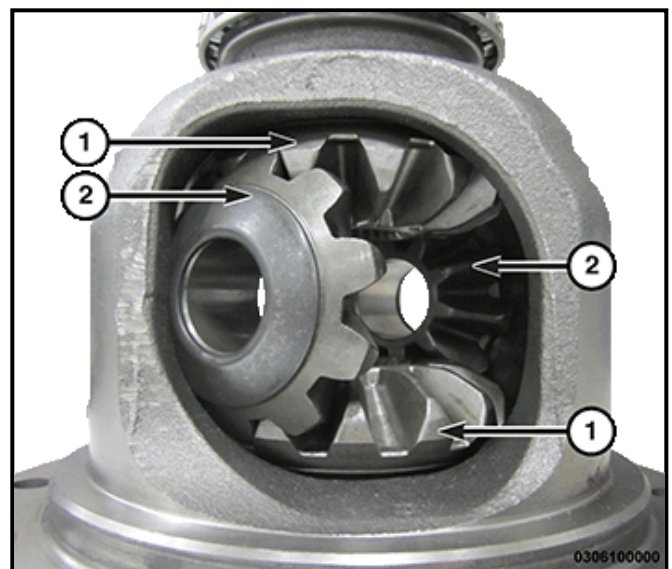

12. Install the pinion mate shaft (2) in the case (1).

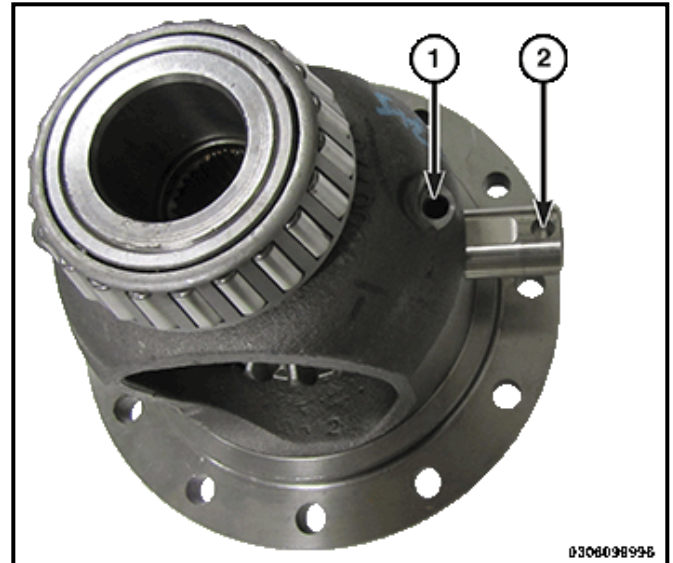

13. Install the pinion mate shaft roll pin (1).

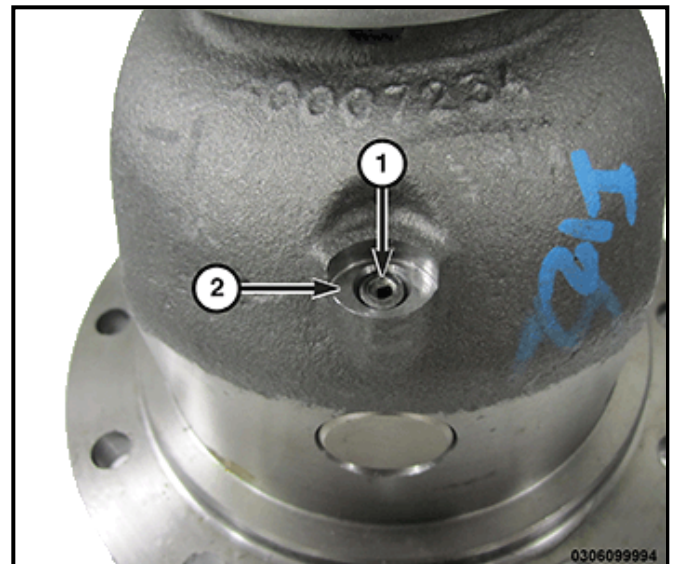

14. Install the ring gear (1) with **NEW** ring gear bolts (2) to the case assembly and tighten to the proper (Torque Specifications) .

15. Lubricate all the differential components with gear lubricant.

