

RIGHT CYLINDER HEAD

REMOVAL

1. Disconnect and isolate the negative battery cable(s) (Refer to 08 - Electrical/Battery System/Standard Procedure).
2. Remove the engine cover (Refer to 09 - Engine/COVER, Engine/Removal and Installation).
3. Removed the bolts (1) and the engine cover mounting bracket.

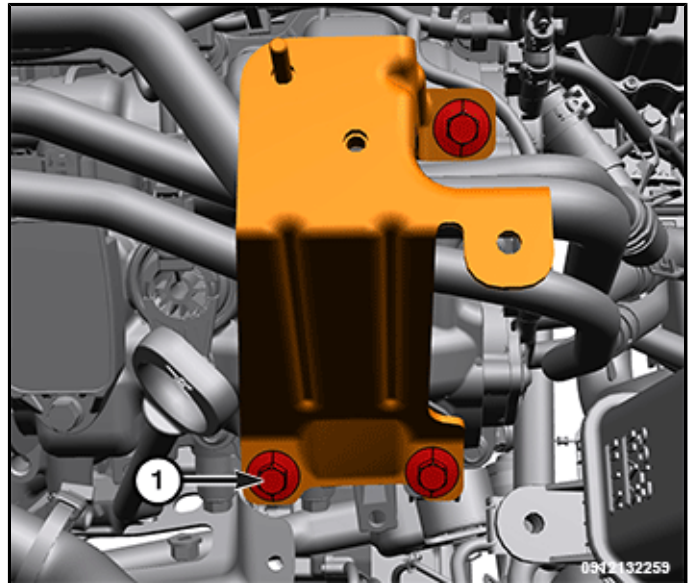

4. Remove heater hose mounting brackets (1) and reposition the heater hoses.

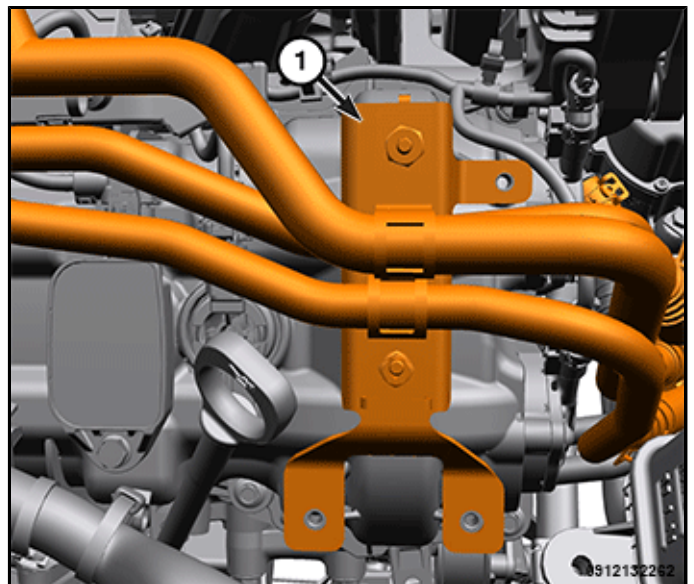

5. Disconnect the wire harness connector(s) (1) from the ignition coil(s).

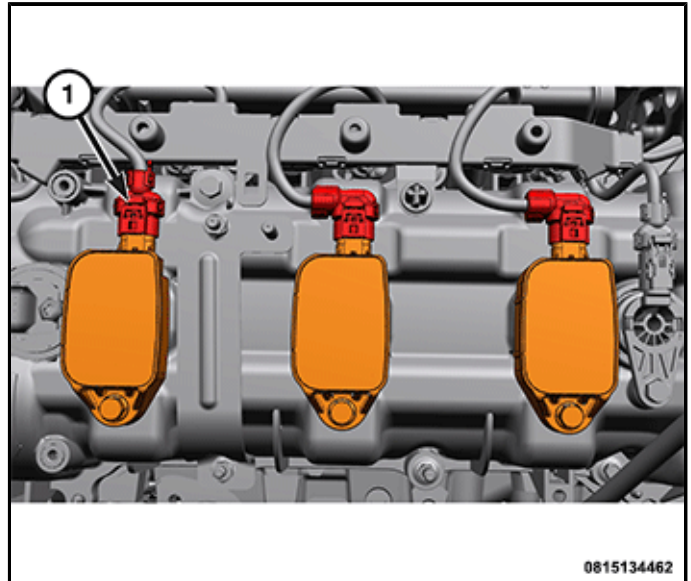

6. Loosen the ignition coil mounting bolt(s) (1).

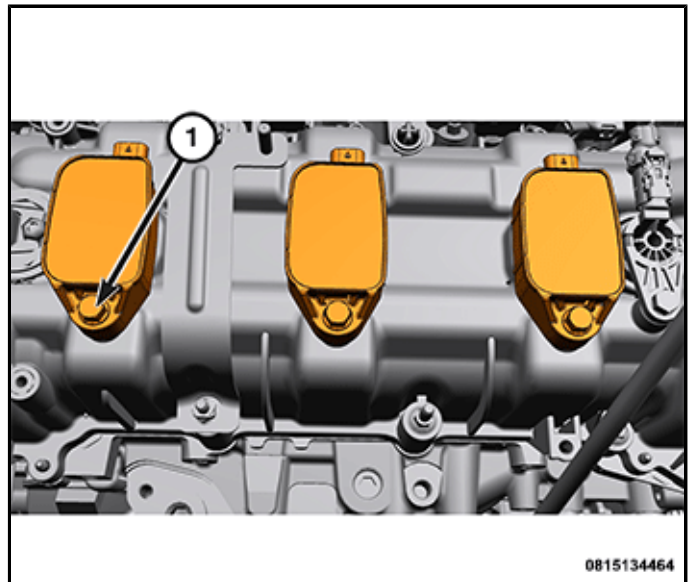

7. Firmly pull the ignition coil upward using a slight twisting motion if necessary.

NOTE: If the boot will not come loose from the spark plug and a tool is necessary to remove it, it is recommended that the coil be replaced.

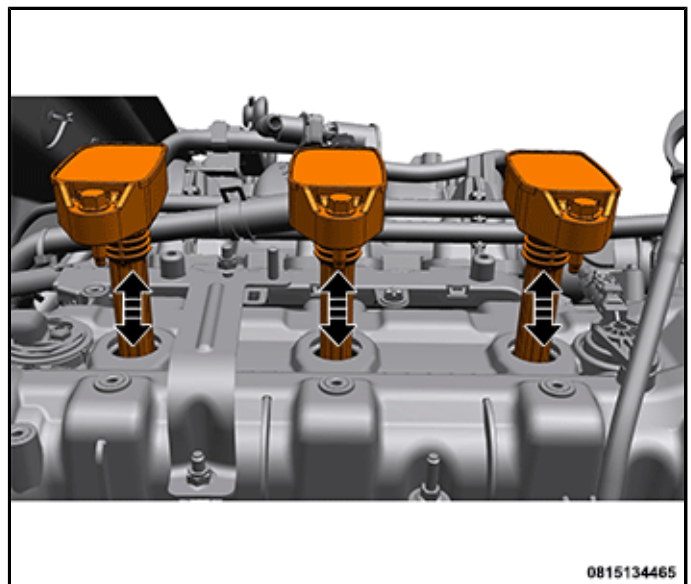

INSTALLATION

1. Inspect the spark plug tube for presence of dirt or contaminants. Use compressed air to remove any debris found. Inspect the spark plug tube for presence of dirt or contaminants. Use compressed air to remove any debris found.
2. Check the condition of the ignition coil rubber boot. Inspect the opening of the boot for any debris, tears or rips. Carefully remove any debris with a lint free cloth.
3. Place a small, 360° bead of **Mopar® Molykote G-5008** lubricant along the inside opening of the coil boot approximately 1 to 2 mm from the chamfer edge but not on the chamfered surface.
4. Insert each coil into a spark plug tube, align the fasteners with the inserts on the cover and apply pressure to seat the coil on to the spark plug before tightening the fastener.

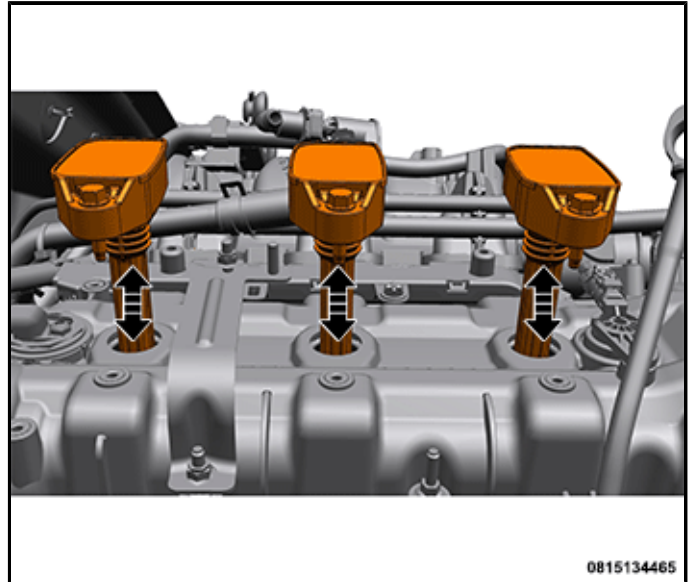

5. Tighten the ignition coil mounting bolt(s) (1) to the proper (Torque Specifications).

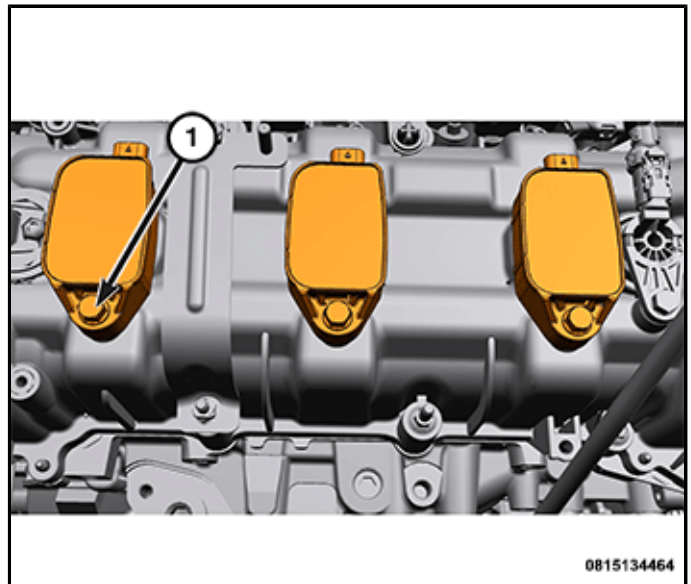

6. Connect the wire harness connector(s) (1) to the ignition coil(s).

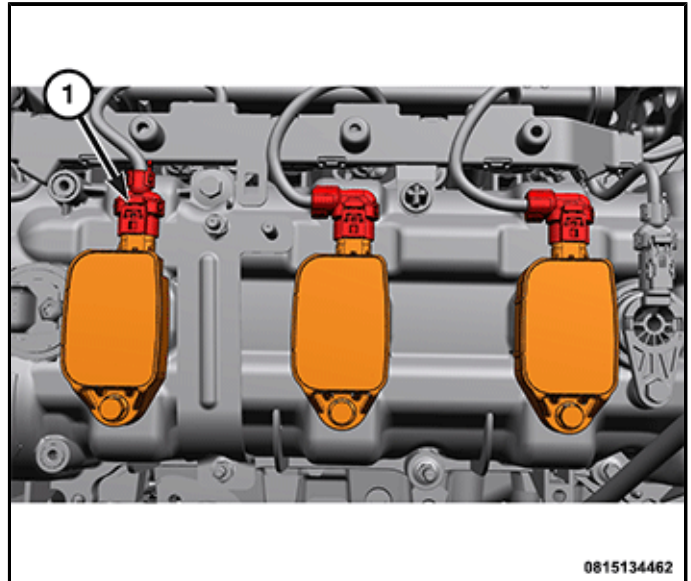

7. Install the heater hose mounting brackets (1) and heater hoses.

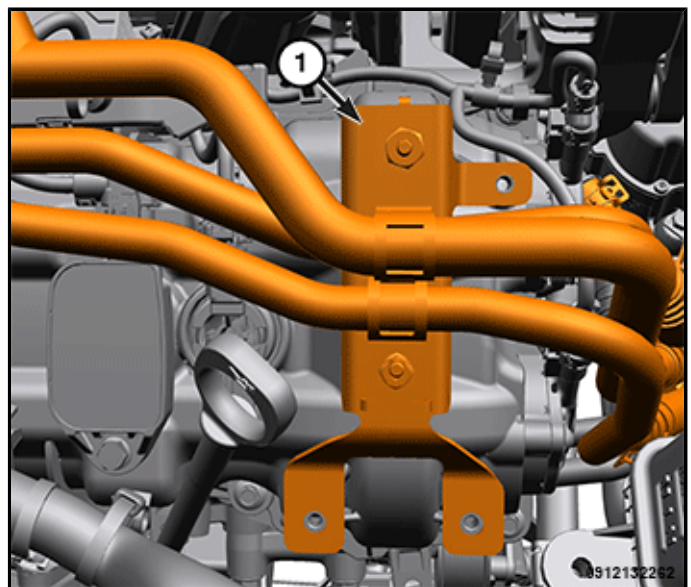

8. Install the engine cover mounting bracket and tighten the bolts (1) to the proper (Torque Specifications).

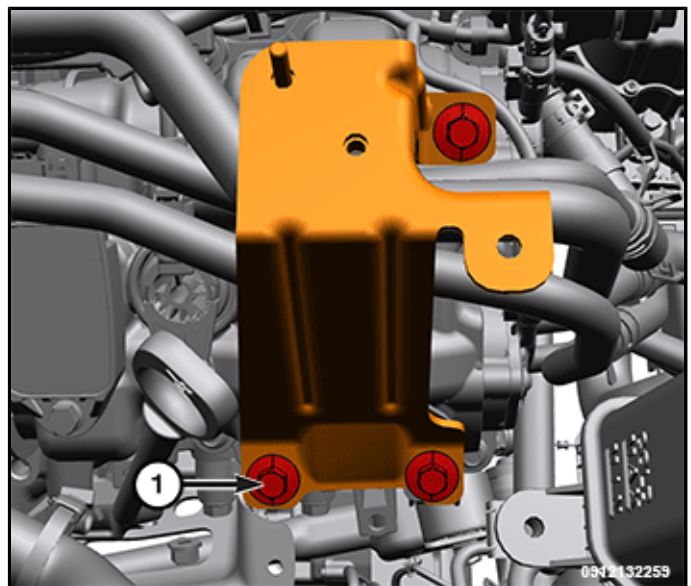

9. Install the engine cover (Refer to 09 - Engine/COVER, Engine/Removal and Installation).

10. Connect the negative battery cable(s) (Refer to 08 - Electrical/Battery System/Standard Procedure).