

RIGHT CYLINDER HEAD

REMOVAL

1. Disconnect and isolate the negative battery cable(s) (Refer to 08 - Electrical/Battery System/Standard Procedure).
2. Remove the ignition coil(s) (Refer to 08 - Electrical/ Ignition Control/COIL, Ignition/Removal and Installation).

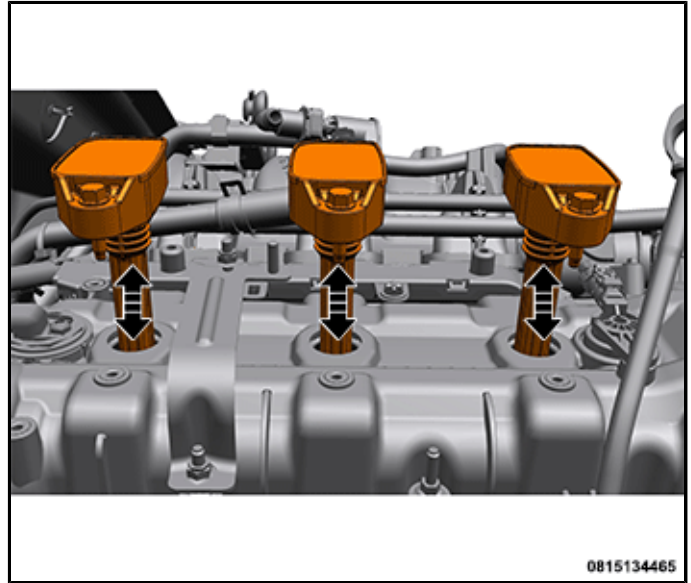

3. Prior to removing the spark plug, spray compressed air into the cylinder head opening. This will help prevent foreign material from entering the combustion chamber.
4. Remove the spark plug from the cylinder head (1) using a quality thin wall socket with a rubber or foam insert.
5. Inspect the spark plug condition.

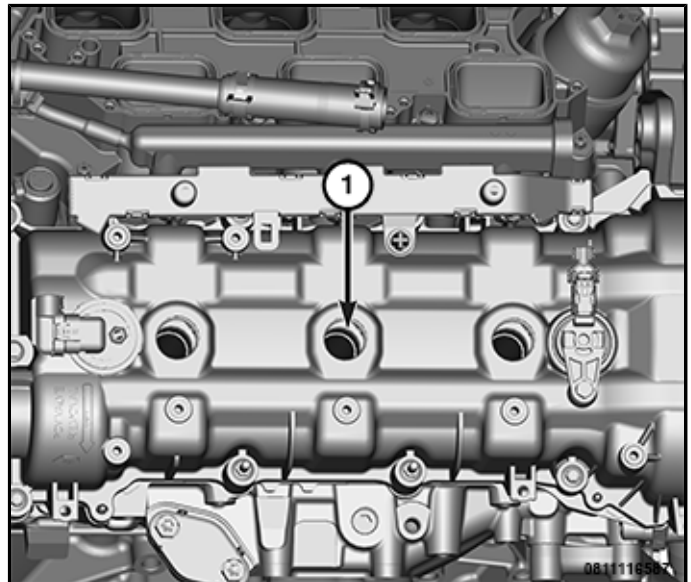

INSTALLATION

CAUTION: Special care should be taken when installing spark plugs into the cylinder head spark plug wells. Be sure the plugs do not drop into the plug wells as electrodes can be damaged.

1. Start the spark plug into the cylinder head (1) by hand to avoid cross threading.

CAUTION: Spark plug torque is critical and must not exceed the specified value. Overtightening stretches the spark plug shell reducing its heat transfer capability resulting in possible catastrophic engine failure.

2. Tighten the spark plugs to the proper (Torque Specifications).

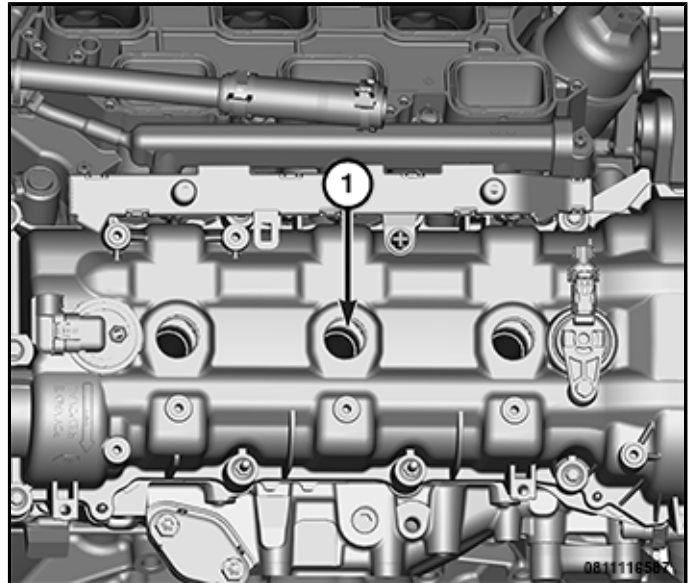

3. Install the ignition coil(s) (Refer to 08 - Electrical/ Ignition Control/COIL, Ignition/Removal and Installation) .
4. Connect the negative battery cable(s) (Refer to 08 - Electrical/Battery System/Standard Procedure).

