

**28 - DTC-Based Diagnostics / MODULE, Drivers Assistance System / Standard Procedure****DRIVER ASSISTANCE SYSTEM MODULE (DASM) VERIFICATION TEST****Diagnostic Test****DRIVER ASSISTANCE SYSTEM MODULE (DASM) VERIFICATION TEST**

---

1. Disconnect all jumper wires and reconnect all previously disconnected components and connectors.
2. With the scan tool, erase DASM DTCs.
3. Make sure that all accessories are turned off and that the battery is fully charged.
4. **If the DASM was replaced or moved in any way, the DASM must be aligned.** Perform the alignment procedure in accordance with the Service Information.
5. Test drive the vehicle and verify proper operation.
6. Using the recorded Environmental Data and the When Monitored Conditions, operate the vehicle in the conditions that set the DTC.
7. With the scan tool, read DTCs.

**Did the DTC return?****Yes**

- Repair the DASM DTC(s). ([Refer to 28 - DTC-Based Diagnostics/MODULE, Drivers Assistance System/Diagnosis and Testing](#)).

**No**

- Repair is complete.

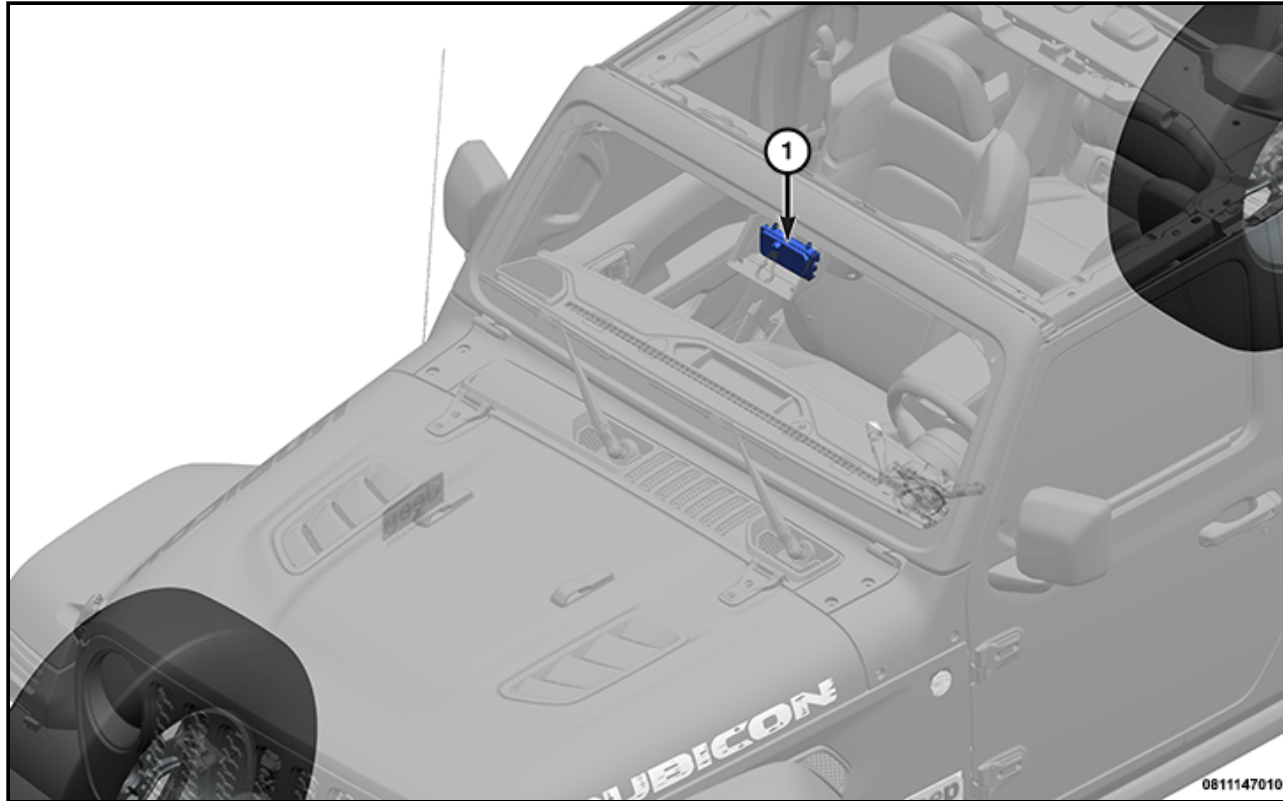
**08 - Electrical / 8E - Electronic Control Modules / MODULE, Drivers Assistance System (DASM) / Description and Operation****DESCRIPTION AND OPERATION****DESCRIPTION**

The interior windshield mounted Drivers Assistance System Module (DASM) (1) includes a camera sensor component and a radar sensor component both housed within a common single module housing. The camera component generally captures camera images of an area in front of the vehicle. The radar component emits fan-shaped radar beams so that objects generally in front of the vehicle reflect the emitted radar back to the sensor. The DASM processes the radar and vision data collected by the corresponding camera component and radar component and processes the information to support the various Drivers Assistance systems equipped on this vehicle.

The DASM communicates with other vehicle control modules via both public and private Controller Area Network (CAN) bus to provide the following features sets:

- Conventional Cruise Control - Only when equipped with a DASM.
- Adaptive Cruise Control with Stop and Go (ACC+)
- Automatic High Beam Control (AHBC)

- Advanced Emergency Braking (AEB)
- Full Speed Forward Collision Warning with AEB (FSRFCW+)

## OPERATION

The DASM uses an integral radar and camera, by means of data fusion, to detect vehicles in the forward path of the vehicle that are moving, stopped or stationary and lane markings on the road.

How the DASM integrated or controls the various Drivers Assistance systems is covered in their respective sections.

- ACC with Stop and Go or Conventional Cruise Control when equipped with a DASM ([Refer to 08 - Electrical/8P - Speed Control/Description and Operation](#)).
- Automatic High Beam Control (AHBC) ([Refer to 08 - Electrical/Lamps/Lighting - Exterior/Description and Operation](#)).
- Full Speed FCW+ ([Refer to 08 - Electrical/8B - Chime/Buzzer/Driver Assist/Description and Operation](#)).

08 - Electrical / 8E - Electronic Control Modules / MODULE, Drivers Assistance System (DASM) / Description and Operation

## DESCRIPTION AND OPERATION

### DESCRIPTION

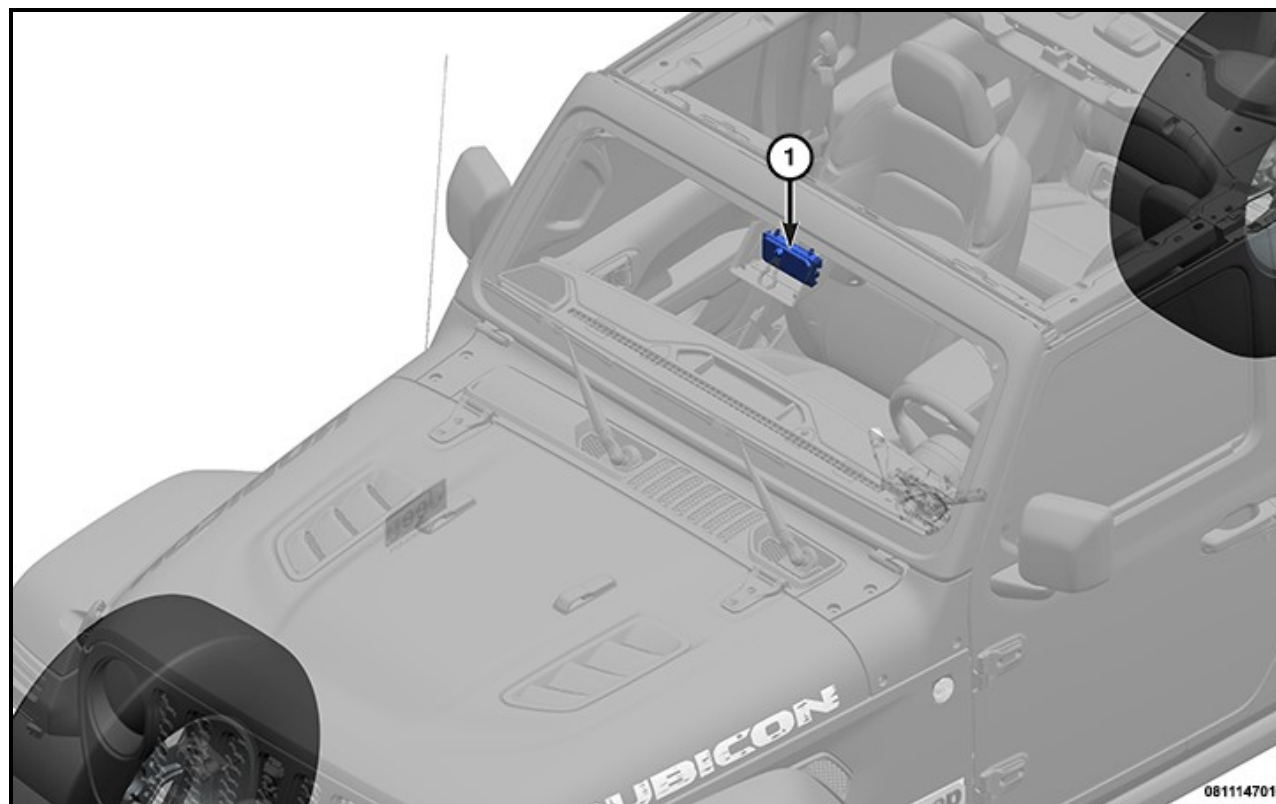

The interior windshield mounted Drivers Assistance System Module (DASM) (1) includes a camera sensor component and a radar sensor component both housed within a common single module housing. The camera component generally captures camera images of an area in front of the vehicle. The radar component emits fan-shaped radar beams so that objects generally in front of the vehicle reflect the emitted radar back to the sensor. The DASM processes the radar and vision data collected by the corresponding camera component and radar component and processes the information to support the various Drivers Assistance systems equipped on this vehicle.

The DASM communicates with other vehicle control modules via both public and private Controller Area Network (CAN) bus to provide the following features sets:

- Conventional Cruise Control - Only when equipped with a DASM.
- Adaptive Cruise Control with Stop and Go (ACC+)
- Automatic High Beam Control (AHBC)
- Advanced Emergency Braking (AEB)
- Full Speed Forward Collision Warning with AEB (FSRFCW+)

## OPERATION

The DASM uses an integral radar and camera, by means of data fusion, to detect vehicles in the forward path of the vehicle that are moving, stopped or stationary and lane markings on the road.

How the DASM integrated or controls the various Drivers Assistance systems is covered in their respective sections.

- ACC with Stop and Go or Conventional Cruise Control when equipped with a DASM ([Refer to 08 - Electrical/8P - Speed Control/Description and Operation](#)).
- Automatic High Beam Control (AHBC) ([Refer to 08 - Electrical/Lamps/Lighting - Exterior/Description and Operation](#)).
- Full Speed FCW+ ([Refer to 08 - Electrical/8B - Chime/Buzzer/Driver Assist/Description and Operation](#)).



3. Repeat step 1 and step 2 until the DASM is within the adjustment specification.



4. After completing the vertical alignment, connect the diagnostic scan tool to the vehicle.
5. Select the "DASM ECU" and then select the "Miscellaneous Functions" tab.
6. Select and run the "DASM Auto Alignment" procedure and follow the on screen prompts to complete DASM calibration.