



HS2

INSTALLATION INSTRUCTIONS

HAVOC HS2

NERF BAR WITH STEP

2020 JEEP GLADIATOR JT 4DR
BLACK POWDER COAT

HPG-56-50004

2020 JEEP GLADIATOR JT 4DR
POLISHED STAINLESS STEEL

HPG-56-52004

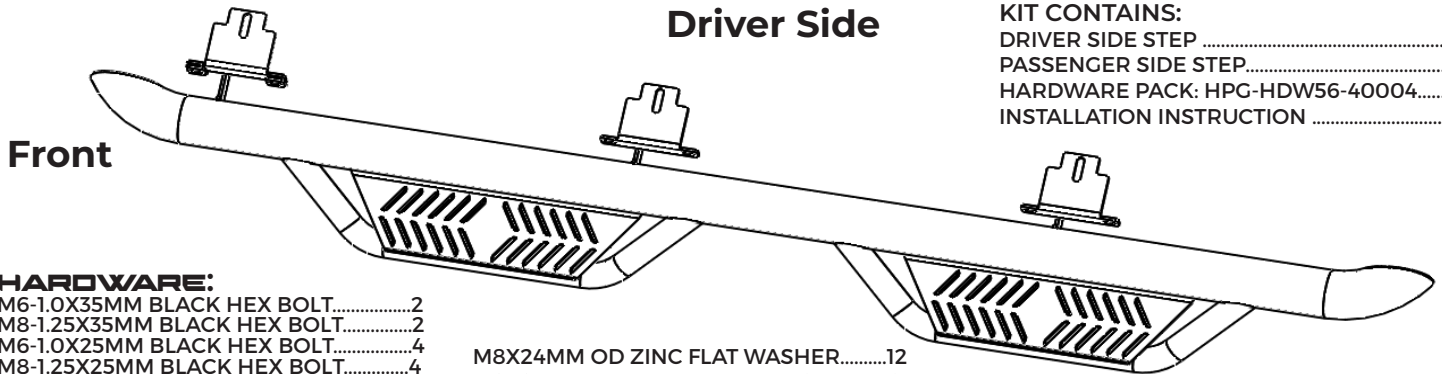

Driver Side

KIT CONTAINS:

DRIVER SIDE STEP1
PASSENGER SIDE STEP.....1
HARDWARE PACK: HPG-HDW56-40004.....1
INSTALLATION INSTRUCTION1

HARDWARE:

M6-1.0X35MM BLACK HEX BOLT.....2
M8-1.25X35MM BLACK HEX BOLT.....2
M6-1.0X25MM BLACK HEX BOLT.....4
M8-1.25X25MM BLACK HEX BOLT.....4
M8 LOCK WASHER, ZINC.....6
M6 SERRATED FLANGE NUT.....6
M8 SERRATED FLANGE NUT.....6

M8X24MM OD ZINC FLAT WASHER.....12
M8X24MM OD BLACK FLAT WASHER.....6
M6X24MM OD BLACK FLAT WASHER.....6
M6X24MM OD ZINC FLAT WASHER.....6

NOTE: PLEASE READ INSTRUCTIONS IN ITS ENTIRETY BEFORE BEGINNING INSTALLATION. VERIFY THAT YOU HAVE ALL COMPONENTS & HARDWARE BEFORE BEGINNING INSTALLATION

STEP 1:

USE THE ILLUSTRATION ABOVE TO DETERMINE THE DRIVER SIDE BAR. THE FRONT OF THE BAR HAS WELDED SPACERS ON THE FRONT BRACKET. WE WILL BEGIN WITH THE DRIVER SIDE BAR. THE FRONT BRACKET WILL USE THE LONGER M8-1.25X25MM BLACK BOLTS IN THE PINCH WELD



STEP 4:

THE MIDDLE & REAR BRACKET INSTALL SIMILAR TO THE FRONT BRACKET. USE THE BLACK M8-1.25X25MM BOLTS, M8 FLAT WASHER IN THE PINCH WELD WITH THE YELLOW ZINC WASHER & SERRATED FLANGE NUT ON INSIDE. INSTALL THE YELLOW ZINC M8-1.25X25MM BOLT, M8 LOCK WASHER & FLAT WASHER UP THROUGH THE TOP OF BRACKET INTO THE UNDER-BODY OF JEEP.

STEP 2:

USE THE BLACK HARDWARE TO INSTALL IN THE PINCH WELD OF TRUCK. THE HEAD OF THE BOLTS WILL FACE TO OUTSIDE OF VEHICLE. THE YELLOW ZINC WASHERS & SERRATED FLANGE NUTS ARE USED ON THE BLACK HARDWARE ON INSIDE OF PINCH WELD.

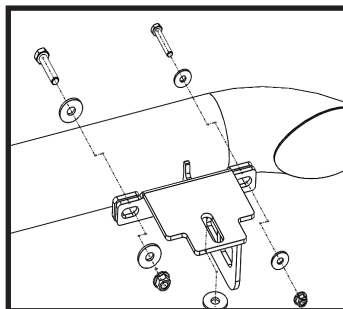

STEP 5:

ONCE ALL THE HARDWARE IS IN PLACE, FULLY TIGHTEN ALL HARDWARE. **TORQUE TO APPROX. 17 TO 18 FTLBS.**

STEP 3:

THE YELLOW ZINC, M8-1.25X25MM HEX BOLT, M8 LOCK WASHERS & M8X24MM OD FLAT WASHERS INSTALL UP THROUGH THE TOP OF BRACKET INTO THE UNDER-BODY OF THE JEEP. **HAND TIGHTEN ONLY, DO NOT FULLY TIGHTEN AT THIS TIME.**

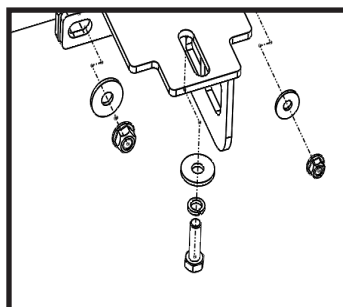

STEP 6:

REPEAT STEPS 2 THROUGH 5 ON THE PASSENGER SIDE OF JEEP. ENJOY YOUR NEW HAVOC HS2 STEPS. AT ANYTIME DURING THE INSTALLATION YOU HAVE ANY ISSUES PLEASE DO NOT HESITATE TO CALL OUR CUSTOMER SUPPORT LINE AT THE PHONE NUMBER LISTED BELOW. THANK YOU FOR PURCHASING HAVOC OFF-ROAD HS2 STEPS. ENJOY!