

MASTERTECH

Pentastar V6 Upgrade Highlights & Master Tech Updates



**REFERENCE BOOK AND TECH NEWS
November 2015**

Table of Contents:

Introduction 2
Master Tech Updates..... 3
Pentastar V6 Upgrade..... 5
2016 Grand Cherokee ESS..... 13

Introduction

This month’s program covers three primary topics.

Master Tech Updates

The Master Tech presentation format has evolved through several advancements.

Starting in 1947, the early programs were produced as filmstrips and records. Videotapes were mailed to dealerships in the 1970s and ‘80s (Figure 1), and the current web-based format was introduced in 2007.



Figure 1: Videotapes of the ‘70s and ‘80s

Continuing the evolution, next month’s Master Tech, while continuing as a web-based program, will introduce a more versatile interface and institute a few changes to the certification requirements.

Pentastar V6 Upgrade

The Pentastar V-6 engine is undergoing a major upgrade for the 2016 Grand Cherokee and Dodge Durango.

The new engine looks quite a bit like the current Pentastar (Figure 2), but nearly every component is redesigned and assigned a new part number.



Figure 2: Upgraded Pentastar

Lessons 2 and 3 of this Master Tech review the key changes, including engine stop/start (ESS) (Figure 3), that allow the upgraded Pentastar to produce up to 14% more torque, with about 6% better fuel economy, and no added weight.

Remember, you should review both this reference book and the online presentation to complete the posttest successfully.



Figure 3: Selectable ESS

Master Tech Updates

Next month’s Master Tech presentation will offer a new look and “feel.”

Primary Format Changes

Closed-captioning text is now displayed in a tabbed menu to the left of the viewport. You can toggle the text display by selecting the menu tab (Figure 4).

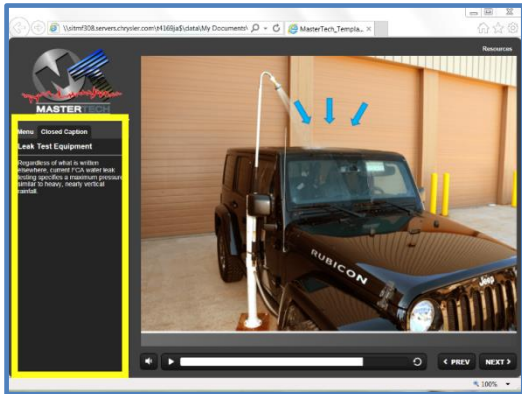

Figure 4: Closed-Caption Text in Sidebar

The “Reference Book/Tech News” link is replaced with a “Resources” link (Figure 5).

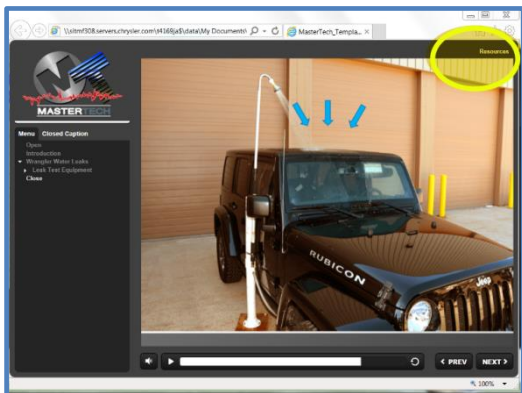

Figure 5: Resources Link

The “Score Summary” button is gone, because you will open the posttest through a different course code.

A simple red “X” button, located in the upper-right corner of the window, replaces the “Save/Exit” button.

The new template allows you to move to any point in the presentation, forward or backward, by using the “Table of Contents” links on the left (Figure 6).

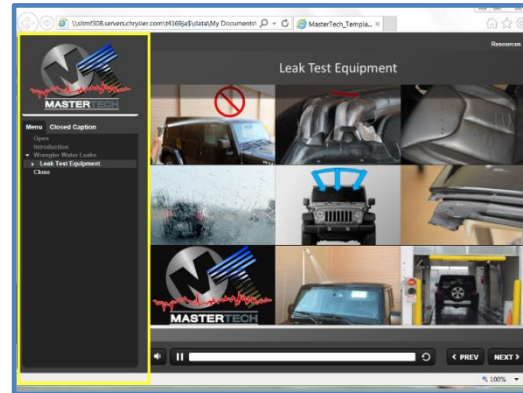

Figure 6: Table of Contents in Sidebar

The seek bar on the bottom of the viewport makes it easy to locate and re-watch any part of the Master Tech (Figure 7).

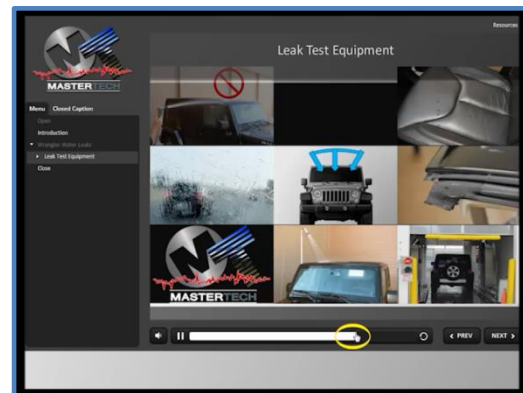

Figure 7: Scene Seek Bar

The new development system allows us greater creativity, including more interactivity and, eventually, compatibility with more devices.

New Posttest Method

The method to open and complete the posttest is very different, because the presentation and posttest have different course codes. For example: The presentation code “MT1512” launches the December 2015 Master Tech presentation.

Table 1: Course and Posttest Naming Method

Type	Year	Month	Posttest?
MT	15	12	Blank or “T”
Master Tech	2015	December	Blank for course “T” for test

The code for the corresponding posttest is the same, but with an added “T” for test. For example, “MT1512T” launches the posttest for the December Master Tech (Figure 8).

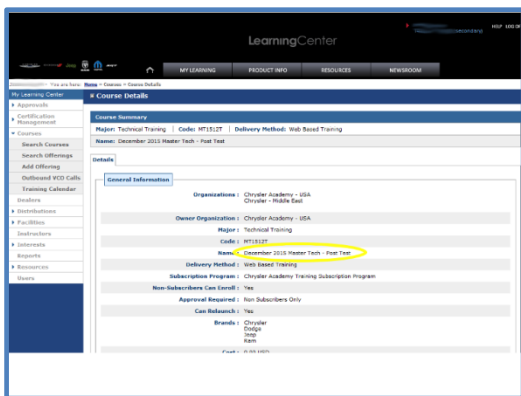

Figure 8: The Test Is Opened as a “Course”

Posttest Completion Within 30 days

Using two course codes allows long-term access to the presentation, with short-term access to the posttest.

Under the current system, some technicians do not complete Master Techs until several months after their publication. So, the technicians may miss timely content.

Now, technicians will have at least 30 days (until the 15th of the following month) to complete the posttest. **You must complete the posttest by the 15th of the following month to earn certification credit.**

Since the posttest is completely separate from the presentation, the new format is ideal for getting together as a group to watch and discuss the Master Tech presentation (Figure 9), and then complete the posttest individually.

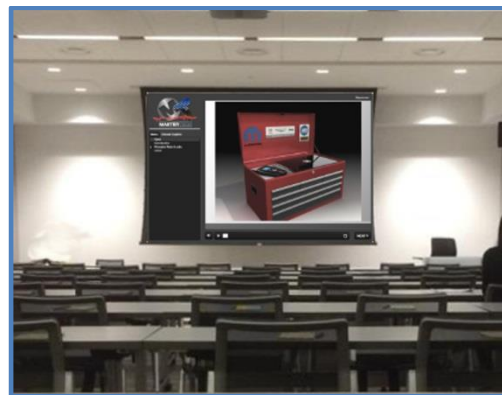

Figure 9: Watch and Discuss Master Tech as a Group

To receive full credit under the new program, technicians must pass nine of the twelve posttests instead of passing all twelve, as required by the current program.

The key objectives of the upgrade are:

- Improved navigation
- More interactivity
- Timely completion of each program

We hope these improvements make Master Tech more helpful and more enjoyable.

Pentastar V6 Upgrade

In the world of engine design, higher torque and lower fuel consumption are key design goals. FCA is introducing an upgraded Pentastar V6 that offers improvements in both areas.

The 2016 Jeep Grand Cherokee and the Dodge Durango introduce a 3.6-liter version of the upgraded Pentastar.

Please note: The stand-mounted Pentastar shown in this reference book and the presentation is a prototype for possible alternate applications. So, accessory components, like the intake manifold and some cooling components, are mounted differently than the engine in the Grand Cherokee (Figure 10).



Figure 10: *The Stand-Mounted Version Is Different than the Grand Cherokee Version*

Pentastar Features and Components

The three-way coolant valve and thermal management unit (TMU) are carried over with few changes from the 2015 models (Figure 11).

Additional coolant lines are required to route coolant through the new cooled exhaust gas recirculation (CEGR) cooler (Figure 12).

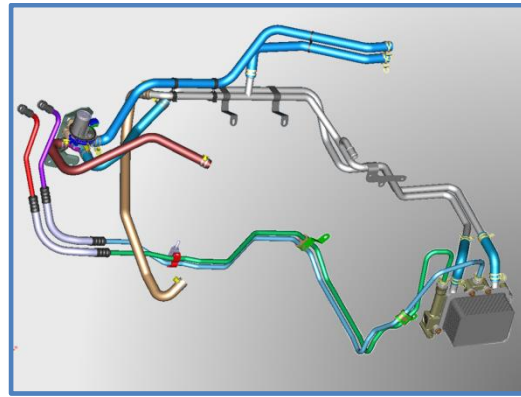

Figure 11: *Cooling Diagram*



Figure 12: *EGR Cooler Lines*

The thermostat is integral to the thermostat housing (Figure 13). During installation, press on the housing to compress the spring until the fasteners are snug to help ensure that the housing is installed correctly.



Figure 13: *Integral Thermostat*

A twist-lock type engine coolant temperature (ECT) sensor is now mounted in thermostat housing (Figure 14). This new location provides more precise temperature readings for advanced thermal management options.



Figure 14: Twist-Lock Coolant Temperature Sensor

New cylinder heads feature larger coolant passage to reduce temperature gradients and improve overall cooling. Also, coolant is routed around exhaust valve guides for greater valve durability.

A new “twist-off” positive crankcase ventilation (PCV) valve and a quick-connect fitting on the PCV tube simplify servicing the system compared to the old style bolt-on valve (Figure 15).



Figure 15: Twist-Off and Quick Disconnect PCV Valve

As part of the new cooled exhaust gas recirculation system, both integral exhaust manifolds include an EGR port (Figure 16). The exhaust gas tube (to the EGR valve) is connected to one port, and a blocker plate is installed on the other port. The application determines which port is blocked and which is used.

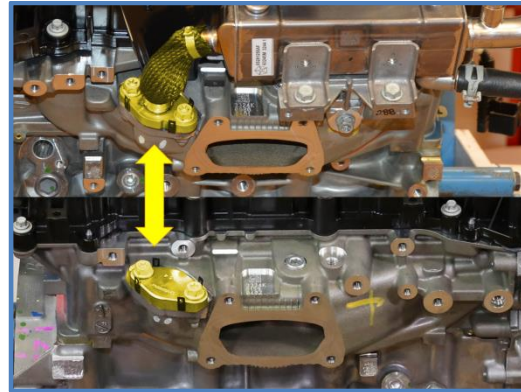

Figure 16: Both Exhaust Manifolds Have EGR Ports

The intake and exhaust valves are shorter and lighter which allows the use of new valve springs to reduce friction losses.

The redesigned variable valve timing (VVT) system allows a greater range of adjustment for the intake timing.

Big news for the upgraded engine is a two-step, variable valve lift (VVL) system for the intake valves. Varying the valve lift for different operating conditions reduces pumping losses and improves drivability. The intake camshaft uses a “tri-lobe” for each valve. The inner and outer lobes have different lift, duration, and centerline specifications. The design provides two camshafts on one axis.

Unique, dual hydraulic intake roller finger followers (RFFs) and unique lifters allow hydraulic control of high and low valve lift (Figure 17).

Note that in various FCA publications, the same part may be called a “lifter” or more correctly a “lash adjuster.”

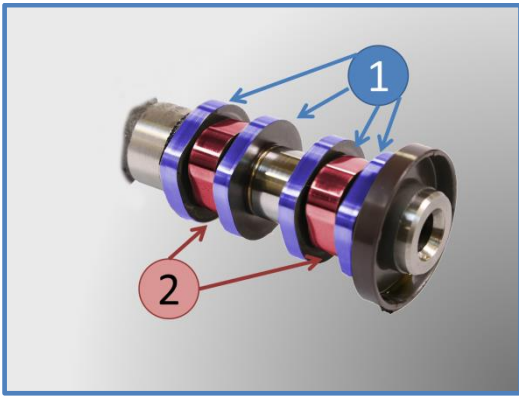

Figure 17: Two-Stage Lift:
1. Low (Outer) and 2. High (Inner)

Two VVL solenoids are mounted on each bank. The front solenoid, mounted on the valve cover, controls hydraulic pressure to the two-stage lifter for the corresponding front cylinder (Figure 18).



Figure 18: Front VVL Solenoid on Each Bank

The rear mounted solenoids control VVL for the corresponding back two cylinders (Figure 19).

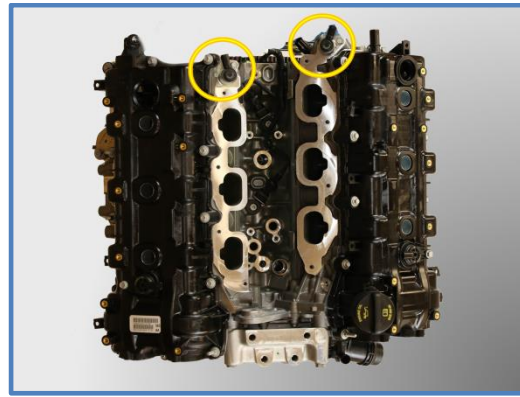

Figure 19: Rear VVL Solenoids

The exhaust valve train uses familiar looking single-lift roller finger followers and lifters. The valve train parts are not interchangeable between the current Pentastar and the upgraded version. Verify the part numbers!

The camshaft position (CMP) sensors are in a familiar location, but they are not interchangeable with the current CMPs.

Compared to the current 4x3 timing chain, the new 3x2, radiused back timing chain is thinner, lighter, and stronger. The new chains improve durability and reduce frictional losses (Figure 20). To match the new chains, the timing sprockets are thinner with a different tooth pattern.

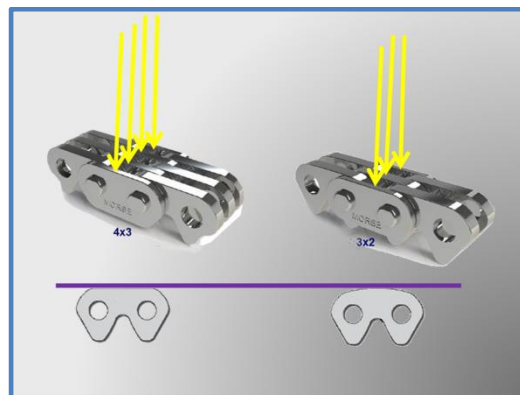

Figure 20: Smaller, Lighter, Stronger Timing Chains

The upgraded Pentastar is the first production engine to feature HG-R1 coated timing chain guides. The coating reduces friction and increases timing chain life.

Block Components

A higher volume, two-stage oil pump is mounted to the lower front of the block and driven by a separate chain. As before, the new pump is electronically controlled for two stages of operation. The current and new pumps are not interchangeable.

The oil is pumped from a one-piece aluminum oil pan. The pan acts as an oil-cooler and adds strength to the bottom end of the engine. Trail-rated vehicles still use a two-piece aluminum and steel oil pan.

The new Pentastar uses 0W-20 oil, which helps economy and is required for the VVT and VVL systems.

While the oil temperature sensor is moved from the oil cooler module to the rear of the right cylinder head (Figure 21), the oil pressure sensor remains on the oil cooler, under the intake manifold.



Figure 21: Rear, Right Head Mounted Oil Temperature Sensor

The upgraded Pentastar has larger, hard-to-miss oil filler on the left valve cover.

To improve efficiency and achieve an 11.3 to 1 compression ratio, the engine uses new pistons with low-tension rings and a carbon-coated, full-floating piston pin. The piston crowns are marked to indicate left or right and grade 1 or 2.

The crankshaft is lighter, with smaller and narrower main and rod journals (Figure 22).



Figure 22: New Crankshaft

The new flywheel and damper are designed to accommodate the ESS feature.

Like the CMPs, the crankshaft position (CKP) sensor is new and not interchangeable with the old CKP.

The new intake manifold features longer runners to increase low RPM torque and relocated vacuum ports for improved efficiency.

New, higher voltage ignition coils add a ground connection and an internal firing circuit to reduce misfires and increase fuel economy. Ignition voltage, ground, and a signal from the powertrain control module (PCM) are connected through the three-terminal connector (Figure 23).



Figure 23: New Ignition Control Method

The new spark plugs have a platinum-tipped ground electrode, iridium-tipped center electrode, and a different reach than the current Pentastar.

Designed to reduce drag and bearing stress, a new belt tensioner is mounted to the front of the engine.

Pentastar Functional Upgrades

The Pentastar upgrade introduces three major changes that deserve a closer look (Figure 24):

- Upgraded variable valve timing
- Two-stage variable intake valve lift
- Cooled exhaust gas recirculation



Figure 24: Three Major New Features

Upgraded Intake VVT

For years, the Pentastar V6 has included camshaft phasers to improve the engine’s efficiency at various speeds. The upgraded system introduces a few design changes to improve performance.

Intake phasers use torque driven, rather than hydraulic, cam phasing to reduce oil demand. The range of adjustment has been increased from 50 degrees to 70 degrees (Figure 25). The increased range mitigates detonation during hot starts and expands the operating envelope of ESS.

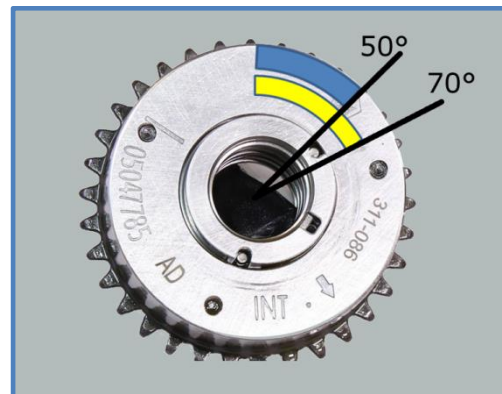

Figure 25: Larger Range of “Authority”

The VVT actuators, which used to be interchangeable, are now specific to intake or exhaust, with one of each mounted on the front of each head (Figure 26). The timing procedure and phaser markings are similar to the current Pentastar.

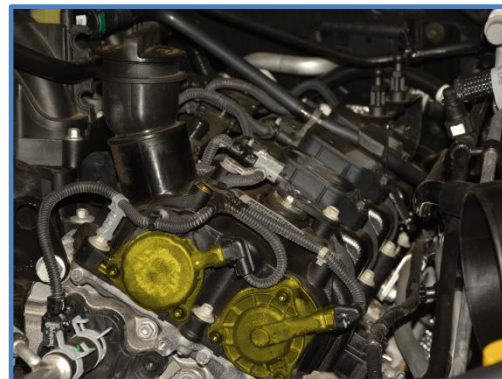

Figure 26: New VVT Actuators

The camshaft-locking tool must be used to remove or install the new torque driven intake phaser (Figure 27). Attempting to hold the assembly by any other method will damage the two-piece phaser.



Figure 27: New Camshaft Holding Fixture

The current camshaft alignment tool will not work with the upgraded engine, because the camshaft centerlines are 4 degrees different. As always, refer to service information for the latest procedures and tool requirements.

New VVL

As mentioned earlier, the intake variable valve lift system introduces three redesigned components:

- Tri-lobe intake camshafts
- Lash adjusters (lifters) with an extra oil path (Figure 29)
- Two-step RFFs (Figure 30)

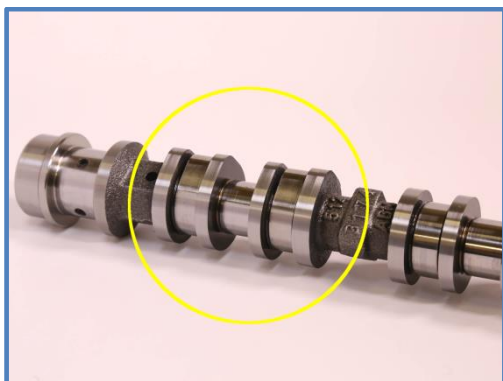

Figure 28: Tri-Lobe Intake Camshaft

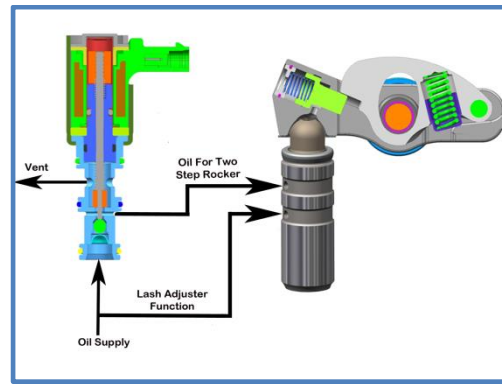

Figure 29: Lifter with an Extra Oil Path (in Low-Lift Mode)



Figure 30: Lifter and RFF

The tri-lobe camshaft uses three lobes for each valve. The two narrow outer lobes are identical. They provide a low lift, short duration intake profile to provide smooth idle and more efficient low-speed operation. The inner lobe has a higher lift, longer duration, and different centerline. This profile provides more power at higher engine speeds.

The PCM controls the normally closed VVL solenoid valves. The system allows a small amount of oil pressure to bleed by the valve, keeping the oil galleries primed to reduce the mode response time.

The intake valve operates from the center (high-lift) lobe when the solenoid valve is closed.

When the PCM energizes the solenoid, the valve opens, and oil pressure moves the spring-loaded pin inside the RFF assembly. This allows the inner mechanism to absorb motion instead of transferring the motion to the intake valve. In this mode, the outer (low-lift) lobes actuate the intake valve.

The front VVL solenoid, mounted on each valve cover, controls the intake lift mode for that head's front cylinder only. The head-mounted rear solenoid controls the lift mode for the head's two rear cylinders.

For diagnostics, solenoid 1 is on the front of the right bank, solenoid 2 is on the rear of the right bank, solenoid 3 is on the front of the left bank, and solenoid 4 is on the rear of the left bank (Figure 31).

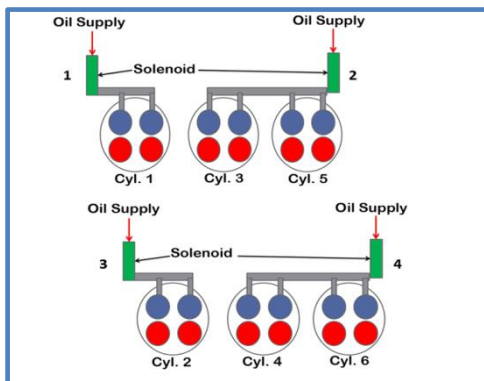

Figure 31: VVL Solenoid Designations for DTCs

New CEGR

Cooled exhaust gas recirculation provides the emissions reduction benefits discussed in recent Master Techs, and enables the new Pentastar's higher compression ratio by reducing combustion temperatures when required.

To accomplish this, the PCM controls the CEGR system, which can route exhaust gases from an exhaust manifold, through the cooler, through the EGR valve, into the intake manifold. Engine coolant absorbs heat from the exhaust gas going

through the cooler (Figure 32). Cooling enhances the system's effectiveness and reduces the wear on engine components.

The PCM monitors the exhaust gas temperature through a cooler-mounted temperature sensor and controls and monitors the motor-type EGR valve through a Hall-effect sensor.

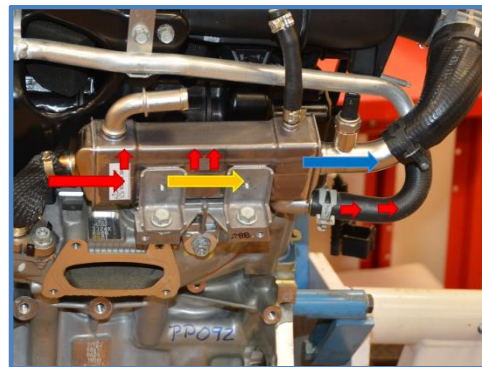

Figure 32: Recirculated Exhaust Gases Through Cooler

Pentastar Diagnostic Changes

The upgraded Pentastar's new components and functions include some new diagnostic trouble codes (DTCs) to help isolate the point of system faults.

The EGR valve connector contains five terminals: Terminals 1 through 3 (sensor return, position signal, and sensor feed) are for the position sensor. Terminals 4 and 5 supply power to operate the motor (Figure 33).



Figure 33: Five-Wire EGR Connector

As with the power window motors we covered last month, the PCM reverses the polarity supplied to terminals 4 and 5 to reverse the direction of the motor and open or close the valve.

The PCM can generate several CEGR, circuit-related DTCs for both the EGR motor circuit and the feedback circuit from the motor. Usually, the descriptions for these DTCs are self-explanatory and include the terms “short,” “open,” “high,” or “low.” They are sometimes referred to as “hard” faults.

With service information’s description of the DTC, a wiring diagram, and a digital multimeter, “hard” faults are relatively easily to diagnose.

As with previous EGR systems, the PCM can also set monitor-based DTCs, which include terms like “EGR performance.” Diagnosing the root cause of monitor-based DTCs requires a good understanding of the system, and close attention to the diagnostic procedures in service information.

Like the cooled EGR, the VVL system introduces some easy to understand electrical DTCs, like “Intake Valve Control Solenoid 3 Circuit High.”

Also, PCM monitors can produce VVL performance DTCs, like “Intake Valve Stuck In High Lift Position,” which require visual verification of the RFFs (Figure 34).

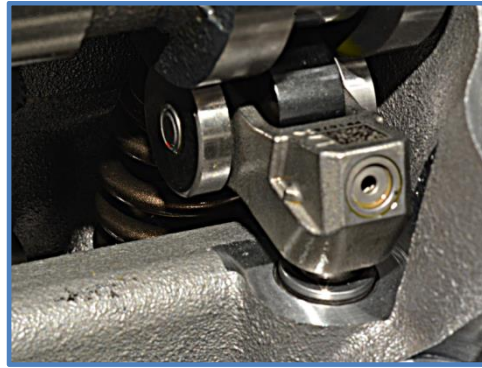

Figure 34: Some DTCs Require Visual Inspection of the VVL Components

The good news is that all three of the new systems include a comprehensive set of new DTCs to help you quickly isolate most system faults.

2016 Grand Cherokee ESS

The 2016 Dodge Durango and Jeep Grand Cherokee offer an engine stop/start (ESS) system with the upgraded 3.6-liter Pentastar engine (Figure 35).



Figure 35: ESS Disable on Center Switch Bank

The ESS system allows the PCM to automatically stop and start the engine when certain conditions are met. The goal is improved fuel economy and lower emissions.

Auto-stop is only activated when the vehicle is stopped and the brake pedal is pressed (Figure 36). As soon as the brake pedal is released, the engine restarts automatically.



Figure 36: ESS Uses the Brake Pedal for Primary Control

ESS-equipped vehicles include a dedicated telltale indicator and may display several different EVIC messages (Figure 37).



Figure 37: ESS Provides Several EVIC Messages

The ESS system uses two batteries: a normal-sized cranking battery and a smaller, AGM vehicle battery (Figure 38).

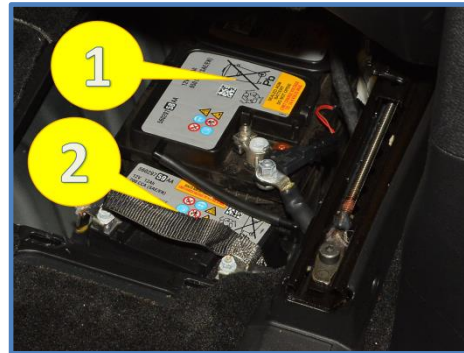

Figure 38: 1. Cranking Battery; 2. Vehicle Battery

In addition to the batteries, ESS-equipped vehicles employ several other unique components, including:

- High durability starter
- Power control relay (PCR)
- Brake vacuum sensor
- Higher output generator
- Intelligent battery sensor (IBS)
- HVAC controller
- Redundant hood switches
- ESS optimized engine mounts

When the ESS system performs an engine stop, the smaller “vehicle” battery keeps accessory features such as the HVAC fan, wipers, headlights, and audio system powered.

The PCM controls the PCR to distribute battery power efficiently, based on engine temperature and power needs (Figure 39). During cold cranking events, the PCR contacts remain closed allowing both batteries to power the starter motor.

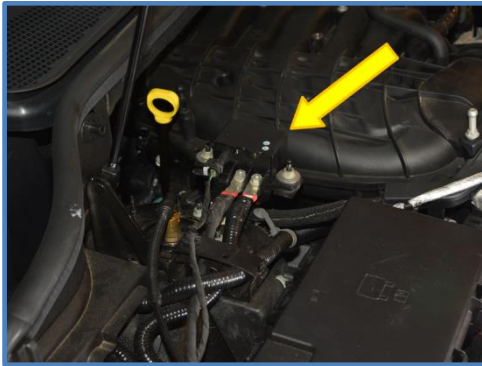

Figure 39: The PCR Is Mounted on the Right Strut Tower

During warm cranking events, the PCM powers the relay to open the contacts, which restricts the starter motor to the cranking battery only.

For an Auto-stop event to occur, the PCM looks at several enablers:

- Is the brake pedal pressed?
- Is the vehicle slowing to a stop?
- Is the coolant temperature acceptable?
- Are the hood and doors closed?
- Is the driver’s seat belt buckled?
- Does the requested cabin temperature require a running engine?
- Are the batteries ready?
- Is the transfer case out of low range?
- Is the system free of any relevant DTCs?

The PCM also monitors:

- Steering wheel angle
- Steering wheel torque
- Ambient temperature
- Time since the last auto-stop
- Electronic stability control system (ESC) status

Always use the charging post and a good ground when battery charging is required (Figure 40). Do not connect directly to any of the battery posts to bypass the IBS. If the IBS is bypassed, the ESS system will not activate until several parameters are relearned.

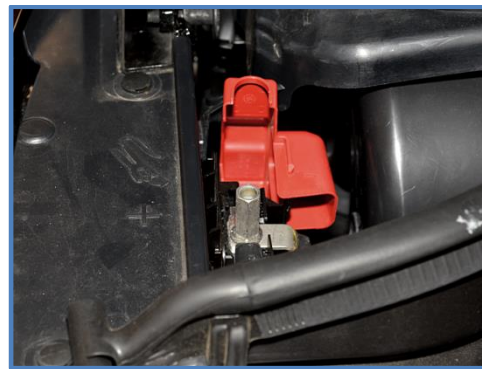

Figure 40: Use the Charging Posts; Do Not Bypass the IBS

Drivers can disable the system using the stop/start disable switch on the center stack. When the ESS system is deactivated, the LED in the button is illuminated (Figure 41).



Figure 41: Illuminated = Deactivated

To prevent an auto-start while the hood is open, a secondary hood switch provides redundant hood position sensing. The secondary hood switch is wired directly to the PCM.

When an auto-stop event is about to occur, the PCM broadcasts a message on the CAN-C Bus, causing the cluster telltale to illuminate (Figure 42).

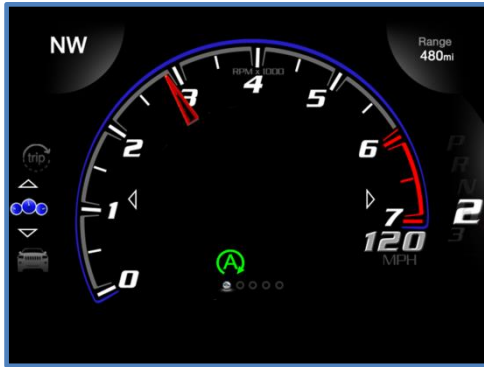

Figure 42: Illuminated = Auto-Stop Active

While auto-stop is activated:

- The telltale remains illuminated.
- The EVIC displays the appropriate auto-stop message.
- Vehicle accessories continue to function normally.
- The electric power steering remains in operation, with reduced assist.

Several conditions can cause the PCM to restart the engine automatically:

- Batteries low
- Brake booster vacuum low
- HVAC request
- Vehicle moving
- Steering wheel turned
- Shift lever moved

Several conditions disable auto-restarting from an auto-stop, requiring a key restart:

- An unbuckled driver’s seatbelt
- An “unsafe” shift selection
- Any of several DTCs

This lesson was designed as a light overview of the ESS system. Always refer to service information for detailed diagnosing instructions.

Learn more

Check out the Learning Center site to find classes covering subjects related to this month’s topics.

Also, do not forget to read the new, monthly STAR Center news. You can find the STAR Center News by logging on to TechCONNECT and clicking the “STAR Center News” link on the left side of the screen.

Next month

Be sure to join us next month when we will cover some manual transmission and clutch issues.

Questions or comments

If you have any questions or comments about a Master Tech presentation, or would like to suggest topics for future Master Techs, please contact us at mastertech@chrysler.com.

Be sure to include your contact information so we can get back to you!

FCA

FIAT CHRYSLER AUTOMOBILES

PERFORMANCE INSTITUTE



Mopar Service & Parts
MOPAR. STICK WITH THE SPECIALISTS®

RAM DODGE CHRYSLER Jeep SRT



National Institute for
**AUTOMOTIVE
SERVICE
EXCELLENCE**



CAP

MOPAR. CAREER AUTOMOTIVE PROGRAM

AUTOMOTIVE
**Youth
Educational
Systems**



SkillsUSA.



**ESSENTIAL TOOLS AND
SERVICE EQUIPMENT**