

**Echomaster  
Terrainview Underbody Universal 4-Camera Kit  
Installation**

I want to give a huge shout out to C.Sco@jlwranglersforums, whose post was the inspiration for my own install. Check out that thread under References.

**References**

- [How To: Install Stinger 4-camera DVR system & Echomaster 7" screen | Jeep Wrangler Forums \(JL / JLU\) -- Rubicon, 4xe, 392, Sahara, Sport - JLWranglerforums.com](#)
- [Upgrade Your Off-roading Experience With Our Revolutionary Underbody Four-camera Kit | EMUBCAMKIT \(youtube.com\)](#)
- [FEATURES: Universal Off-Road Underbody Four-Camera Kit with Built-In DVR | EMUBCAMKIT \(youtube.com\)](#)
- [Tips to Routing Wires Under a Vehicle - YouTube](#)

**Components**

- [Echomaster Terrainview Underbody Universal 4-Camera Kit with DVR \(EMUBCAMKIT\)](#) \$399
- [Stinger Multi-Configurable HD Universal Camera Kit \(PHD5N1\)](#) \$159
- [Echomaster 7" AHD Monitor \(PMON-7022-AHD\)](#) \$127
- [Hoolcar Grab Handle Cell Phone Holder Mount for JL & JT \(HOOLCAR00506\)](#) \$33
- [RAM Mounts Ball Adapter with 1/4"-20 Threaded Post - B Size 1" Ball \(RAM-B-237U\)](#) \$11
- [RAM Mounts Track Ball with T-Bolt Attachment - B Size 1" Ball \(RAP-B-354U-TRA1\)](#) \$15
- [RAM Mounts Composite Double Socket Arm - B Size Short \(RAP-B-201U-A\)](#) \$11
- [Daystar Universal Firewall Boot - 3/8" to 1" Diameter \(KU20040BK\)](#) \$15
- [Del City #5152 Rubber Grommets 1/4" ID, 1/8" Groove Width, 1/2" OD \(25-pak\)](#) \$14

**TOTAL** **\$784**

**Other Tools/Parts Used**

Wire nippers, Wire strippers, Crimping tool, Fish tape wire puller, 16awg, 2-conductor wire, Non-marine grade heat shrink tubing (various sizes), Zip ties (Long, medium, short)

**Pre-Installation**

**Components Needed for Install**

The following components from the EMUBCAMKIT are needed:

- IR/Display Mode Harness
- Camera Extension Cable
- Camera Input Adapter
- Interface Power/Trigger Harness
- IR Remote Control
- Video Output Harness

- Camera/Video Interface
- AHD Cameras
- USB Cable
- RCA cable

The following components from the PMON-7022-AHD are needed:

- 7" AHD Monitor
- Main Harness
- Camera Adapter Harness

### Markup Layout

**Blue box** (lower-center) -> Monitor main video harness -> Ground/Power wires: Both are used. The pigtailed female power connector is not used.

**Green box** (lower-left) -> Monitor video adapter harness -> Ground/Power wires: Not used.

**Red box** (upper-right) -> Video output harness -> Blue reverse trigger wire: Not used.

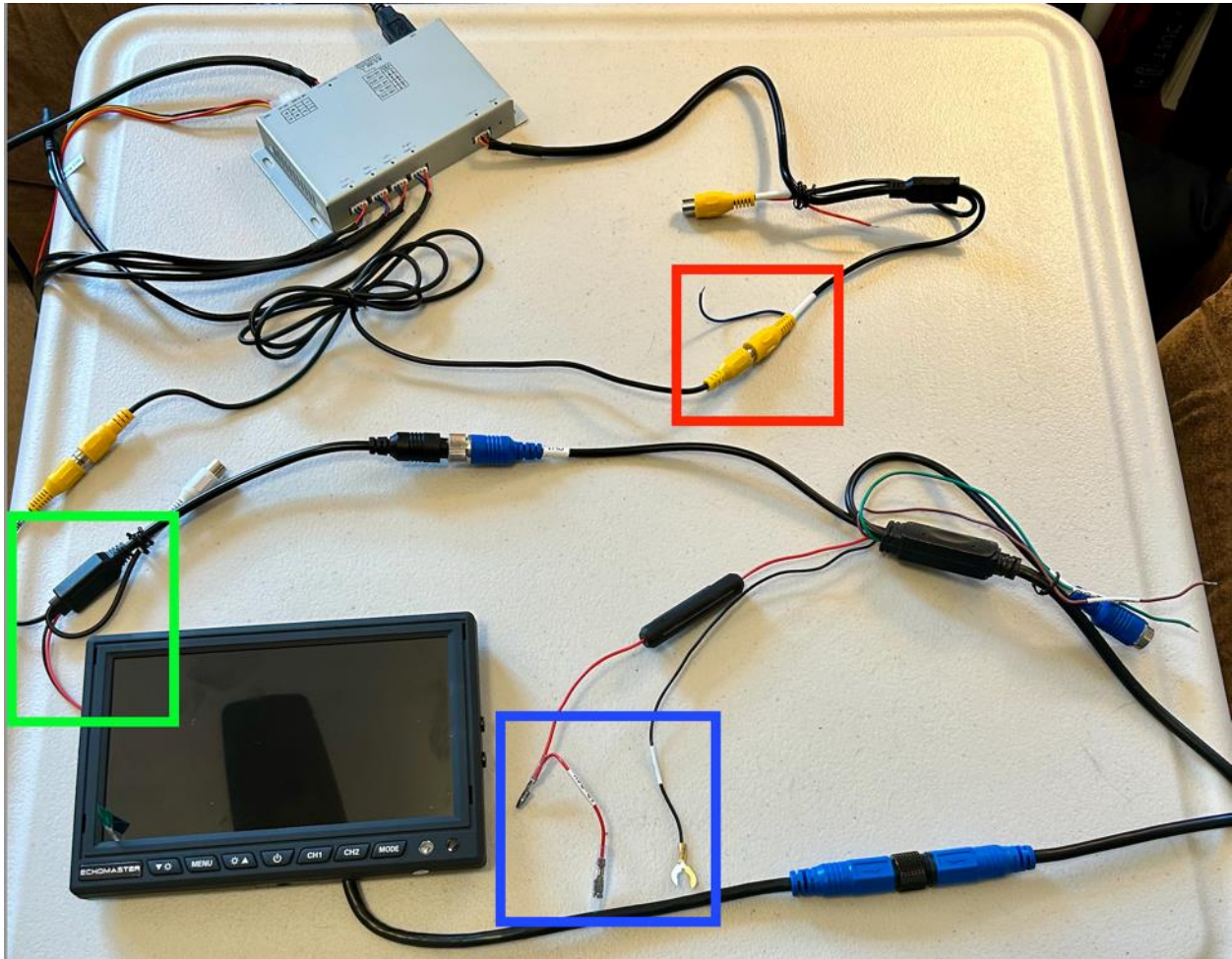

*Markup Layout Diagram*

Use the AHD connector on both the video interface's output harness and the monitor's main harness.

## De-Pin the Video Interface Molex Connector

I De-pinned the unused Pink, Orange, Green & White wires from the molex connector. This is optional, but makes wire management easier. You can also just cut and insulate the ends of the unused wires if preferred.

On the 8-pin power harness, only the following three wires are used:

- Yellow – Constant +12V
- Red – Switched (ACC/Ignition) +12V
- Black – Ground (-)

The four trigger wires are not used:

- Pink - Left (Cam4)
- Orange – Right (Cam3)
- Green – Rear (Cam2)
- White – Front (Cam1)

8-pin power harness configuration from viewing back of the molex connector:

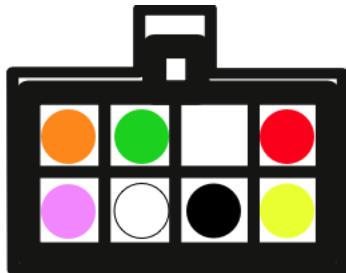

*Molex Connector Diagram*

## How-to De-Pin a Molex Connector

A. Use two staples and cut one side off each to make them 'L' shaped.

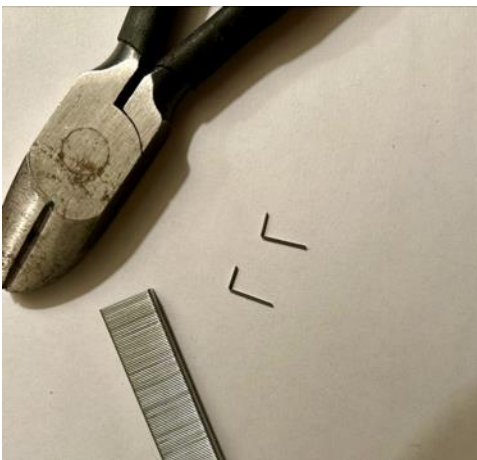

- B. Push one down on each side of the pin to compress the retaining barbs.

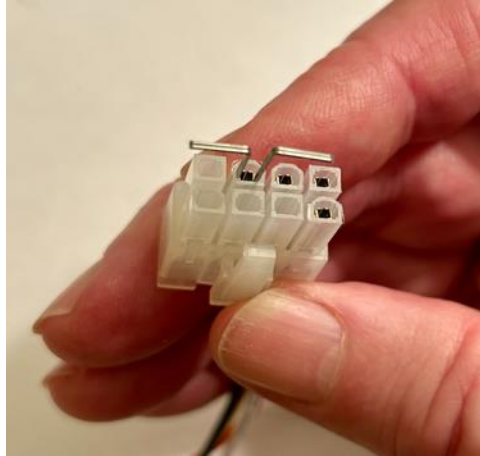
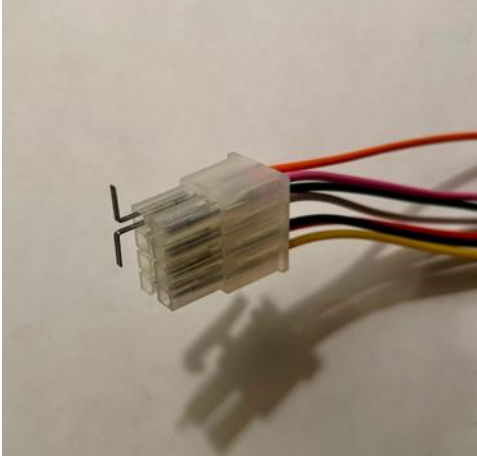

- C. Gently pull the pin out by the wire.

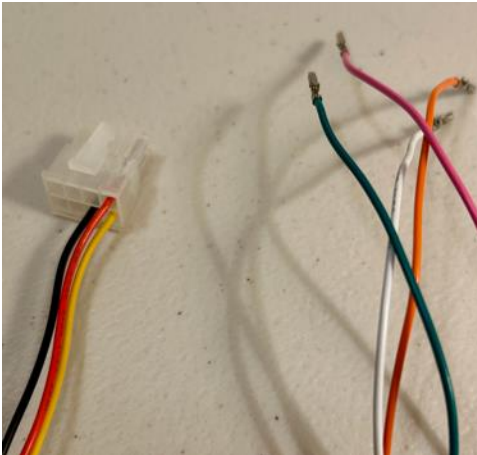

### **Interface Power/Trigger Harness**

The main harness has constant power, accessory and ground wires, which need to be connected. The red wire should be connected to a constant 12V+ source for the video interface to retain its memory settings.

From the video interface 8-pin molex connector,

- A. Connect the Black wire to Ground.
- B. Connect the Video Interface (Red) and Monitor (Red) wires to AUX 4 (Dark Blue/Pink) wire or an Accessory/Ignition. (A +12V source that turns ON-OFF with the key).
- C. Connect the Yellow Wire to BATT or any Constant +12V.

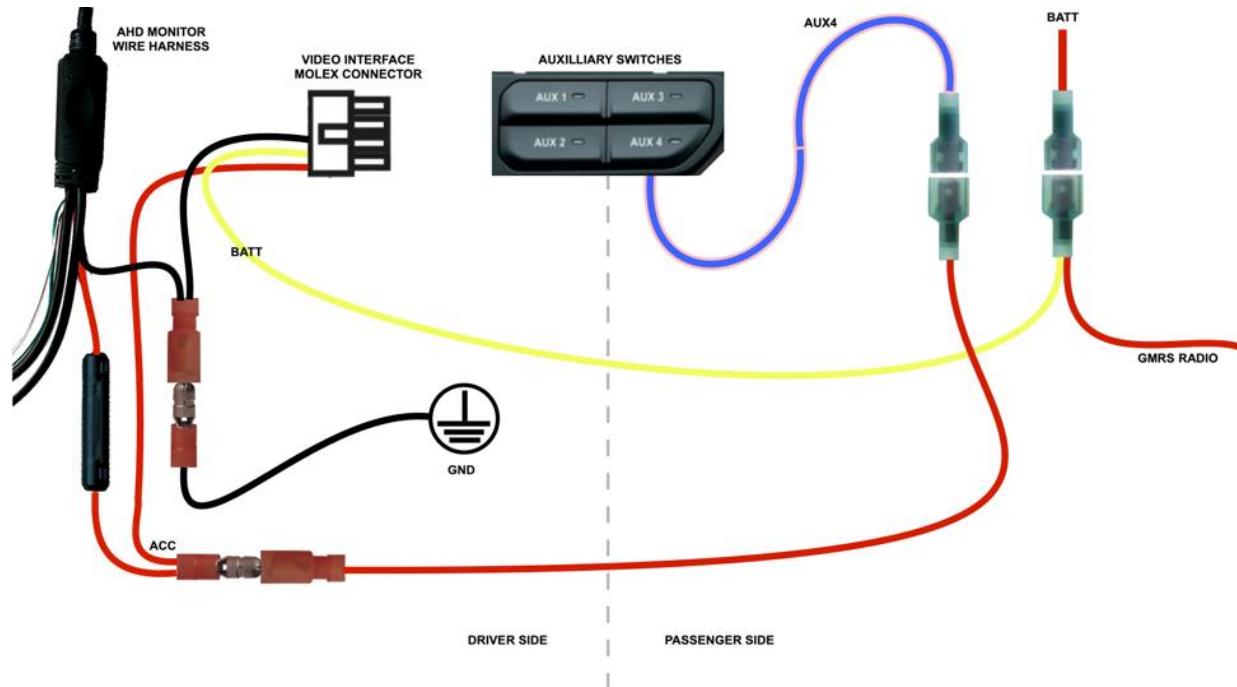

*Power Connectors Diagram*

Insulate with shrink tubing any reverse triggers that are not used in the installation. I also used shrink tubing on the CVBS connectors that don't get used for this install, just to make identify the correct connections when installing. Non-marine grade shrink tubing was used so that it can easily be cut off later if for some reason those connectors are needed.

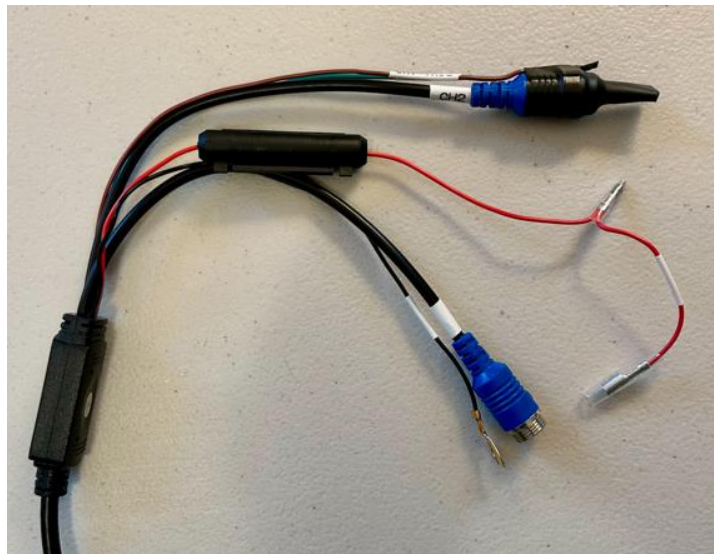

**Prepare source power**

Strip the insulation from the ends of the battery direct and AUX 4 wires on the passenger side. Crimp connectors to all wires as in the *Power Connectors Diagram* previously shown.

## Video Interface DIP switches

DIP switches 1-2-3-4 on the side of the module correspond to Camera Inputs 1-2-3-4. For any camera that is facing towards the rear of the vehicle, set the DIP switch to the UP position. This will “mirror” the video so it is viewed correctly on the monitor.

DIP switch 5 and 6 sets the Video Output Type. The default setting on initial power up is CVBS NTSC. I changed the Dip switches for AHD 25FPS because I thought it offered slightly better color contrast than the AHD 30FPS setting.

The 4 camera positions are:

- |   | DIP Switch |
|---|------------|
| 1. Forward facing, on <b>bullbar</b> looking at ground ahead: | Down       |
| 2. Rear-facing, looking at the <b>rear</b> differential:      | Up         |
| 3. Forward-facing, looking at the <b>left</b> front tire:     | Down       |
| 4. Forward facing, looking at the <b>right</b> front tire:    | Down       |

Video Output Type	Video Quality	DIP 5	DIP 6
AHD 30FPS	Good	UP	UP
AHD 25FPS	Improved color contrast	UP	DOWN

### AHD 30FPS



### AHD 25FPS



Once everything is installed, set the Monitor Input Type to **720p 30fps** from the Settings menu option, even if Dip switches are set to AHD 25FPS.

## Installation

### Route Monitor Cable

Start by removing the instrument panel endcap using a plastic trim removal tool.



Next, route the long monitor adapter cable from under the driver's A-pillar grab bar, down the side via the opened endcap.



Remove the door wiring harness panel, exit the monitor cable there. Replace the door wiring harness panel and the instrument panel endcap.



### Mount Monitor

Disassemble the Hoolcar Grab Handle Cell Phone Holder. You just need the A-Pillar grab handle base mount that is included. Screw the 1" ball mount into the base 1/4-20 threaded hole. Tighten it down as much as you can. Insert the included A-Pillar screw. It is now ready to install on the A-pillar grab handle.



Next, remove the six tiny screws holding the metal T-slot bracket to the back of the monitor. Remove the T-slot so that you can insert the RAM T-bolt. Screw the T-slot bracket and T-bolt back onto the monitor. Tightly screw the RAM Track Ball onto the T-bolt, keeping the T-bolt as high up on the back of the monitor as possible.



Using a plastic trim removal tool, remove the A-pillar grab handle's bottom cover.



Remove the OEM grab handle base with a 10mm socket, then install the new base using a 5mm allen wrench.



Now, connect the two ball mounts together using the RAM Double Socket Short Arm. Tighten the socket arm bolt very tight so that the monitor stays in place. Connect the monitor to the long monitor adapter cable.



What's perfect about the Hoolcar grab handle base mount, is the ball mount screws into the rear of the base rather than the front-end, which allows for space between your hands on the steering wheel and the front of the monitor.



## Mount Video Interface

From inside the cab, on the driver's side where the long monitor adapter cable exited, you will need to push out the the firewall plug. Push the driver's seat all the way back to reach up in there. It is an awkward reach, so do your yoga stretches first.



That hole exits into the engine bay right next to the brake master cylinder.



Place the video interface into the pocket there behind the metal bracket. The adapters and connectors can be stuffed into the pocket between that bracket and the plastic kick panel in front of it.



### Mount IR remote sensor, Display Mode button and USB Cable

The IR remote sensor needs to be in line of sight of the wireless remote control to operate. I routed the cable behind the carpet behind the brake and accelerator pedal to the right side of the dash on the driver's side. Clean the surface to be mounted on with isopropyl alcohol and let dry. The IR remote sensor is mounted using double-sided foam tape.



Route the cable for the display mode button using the route behind the footwell carpet up to near the transfer case shift. The Mode button already comes with double-sided tape attached. This button cycles through the available 15 camera views when pressed.



I routed the USB cable along the back of the steel bar under the plastic steering column cover. It is hanging down below just to make visible in the first picture below. I exited the USB cable as shown in the second picture below.

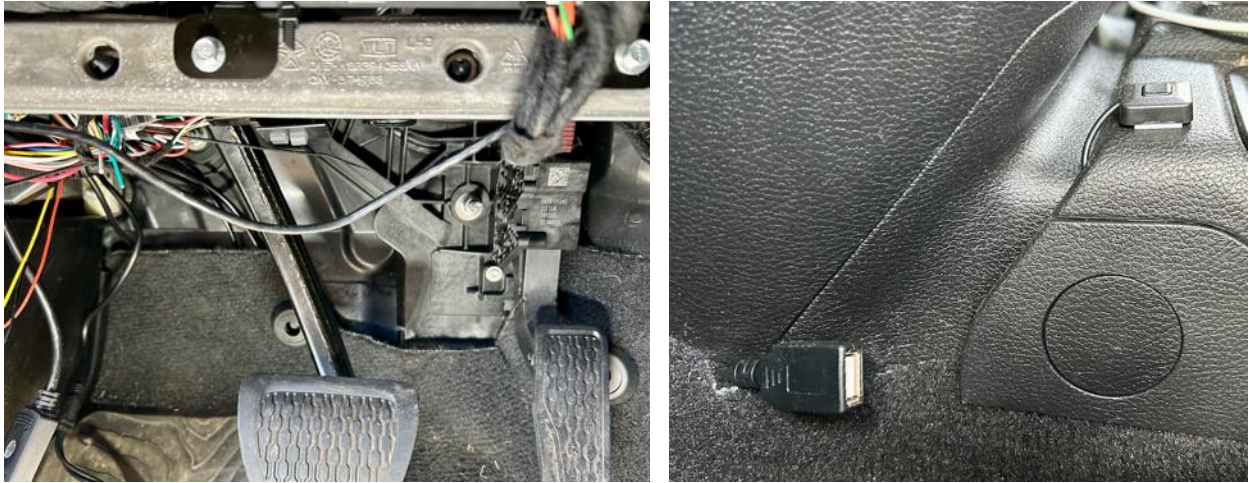

### Connect Wires to Power and Ground

The main video interface harness has both constant power, accessory power and ground wires. I connected the power, accessory and ground wires per the *Power Connectors Diagram* previously shown. All wires were crimped using either the supplied bullet crimp connectors or additional ones I purchased at the auto parts store.

### Mounting The Cameras

#### Camera Locations

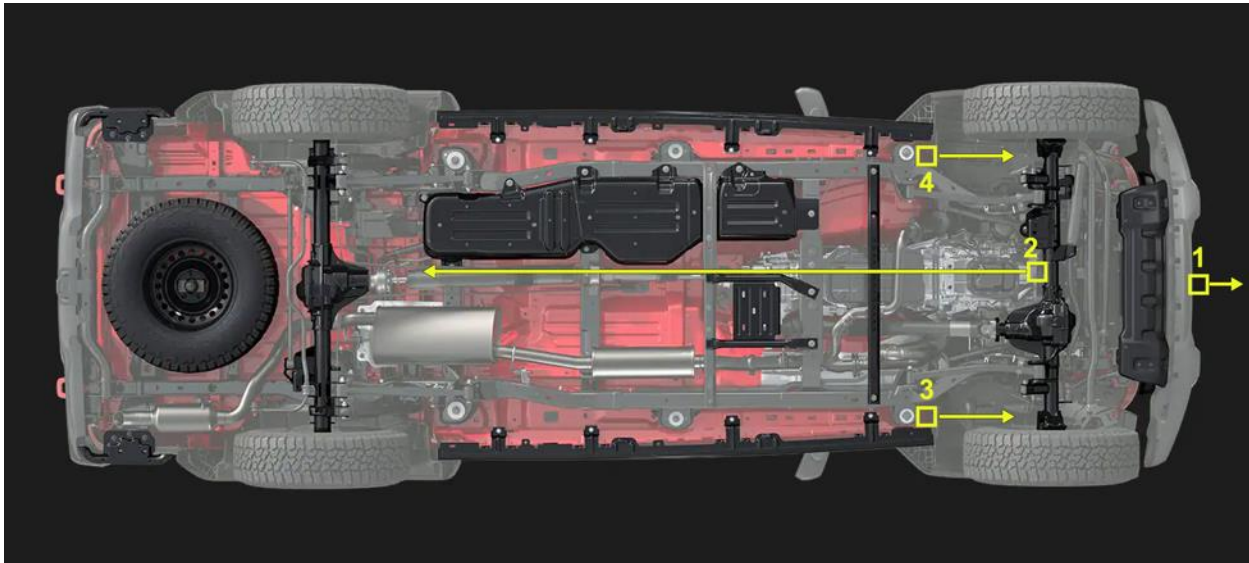

Yellow boxes and arrows show camera location and viewing direction.

Cam#	Location	Cam Screw Hole	Cam Direction	Viewing
1	Bullbar	Top	Forward	Ground ahead
2	Front Axle Tube	Top	Rear	Rear differential/tires
3	Left A-Pillar Body Mount Bracket (Driver side)	Bottom	Forward	Left front tire
4	Right A-Pillar Body Mount Bracket (Passenger side)	Bottom	Forward	Right front tire

The cameras come mounted to the camera brackets using the camera's top screw hole. Cameras 3 and 4 screws were relocated per the chart above. I lost one screw when moving it, but was able to replace it with an M3-0.5 x 16mm Phillips pan head machine screw, which I got from my local ACE Hardware store.

Temporarily position the cameras in the areas you would like to view and temporarily route the camera cables through an open driver or passenger window to the video interface. Hook up the system camera wire to the video interface to view it on the monitor. Only permanently mount the camera once you are happy with the camera view.

#### Camera 1 – Bullbar

1	Bullbar	Top	Forward	Ground ahead
---	---------	-----	---------	--------------

I used a small vice to bend slightly bend the front camera bracket to the contour of my bulbar.



I removed the bulbar and ran the camera wire through a 3/8" hole I drilled in the bottom-center of bulbar using a step bit. Removing the bulbar made the job a lot easier. To avoid damaging the camera wire, I ran the wire through the center hold in the grommet, then inserted it into the hole by pushing in one side and continuing around the edges until fully seated.



The only grommets I could find with the proper dimensions are Del City #5152 Rubber Grommets.

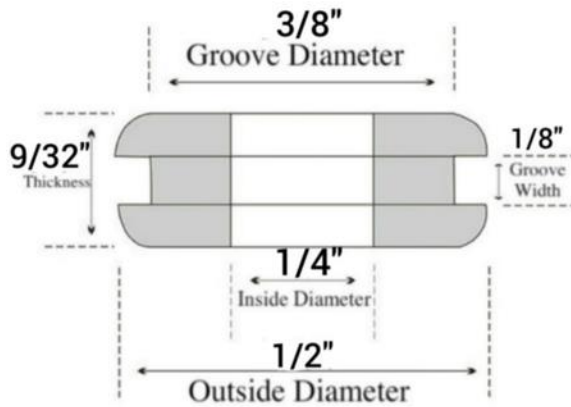

I cleaned the area to attach the camera with isopropyl alcohol and attached the camera with the supplied 3M adhesive pad. I then secured it with zip ties.



I ran the camera wire through the bulbar tube down the driver's side and out through a screw hole in the bumper that gets covered by the base of the bulbar, but is not actually used. I have the Grimm Offroad Mid-Hoop which only uses two of the three bolt holes. You can see the camera wire exiting on the left side of the first pic below. From there, the wire was run under the Maximus-3 Filler Plates to the outside of the frame and up to the engine bay. The wire was then routed over to the firewall via an existing wire harness (see second pic below).



Per post from C.Sco @jlwrangersforums:

Be VERY careful routing the wires along the undercarriage, you need to make sure that 3 important rules are followed:

1. Keep the wires at least 3 inches away from anything hot, especially exhaust parts.
2. Don't attach to anything that rotates, like a driveshaft.
3. If you're tying the cable to parts that move independently (for example the frame, engine, axles, and control arms all move independently in relation to each other) then make sure you've got enough slack in the camera wires to accommodate this movement!

### Camera 2 – Front Axle Tube

2	Front Axle Tube	Top	Rear	Rear differential/tires
---	-----------------	-----	------	-------------------------

I'm currently running a stock Jeep JT Rubicon with no lift, so my chassis does not sit high enough to actually see my rear diff and tires at this time, but I thought it worth at seeing what large rocks are passing underneath so I can approximate their location relative to the diff and tires.

I mounted the camera as low as I felt that it would still get some protection from large rocks. If I had mounted it at the bottom of the axle tube, I might have had a partial view of the diff and tires, but the camera would have been in a very vulnerable to damage. Eventually I will get a 2.5" lift and will likely move the camera higher toward the middle of the axle tube. Also, I will replace the zip ties, securing the camera brackets to the axle tube, to with stainless steel adjustable hose camps at a later time. The tube diameter is 3".

You can see from the pic below that I ran the camera wire across the tube and FAD wire harness and then up to the back corner of the engine bay next to the passenger side firewall.

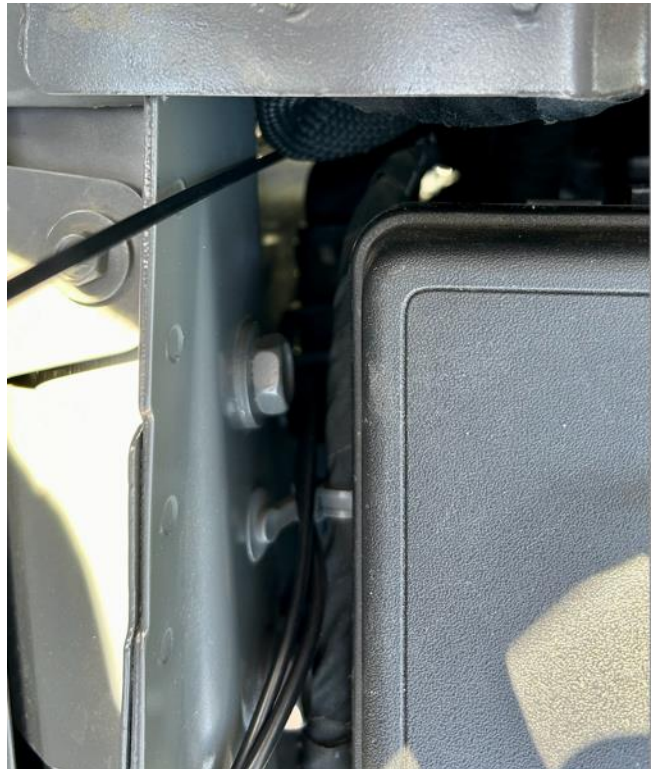

**Camera 4 – Right A-Pillar Body Mount Bracket Driver Side**

4	Right A-Pillar Body Mount Bracket (Passenger side)	Bottom	Forward	Right front tire
---	--	--------	---------	------------------

I mounted camera #4 before #3, so I am documenting it here in the same order.

I ran the camera wire through a rubber grommet inserted into the existing 3/8" hole of the passenger-side A-Pillar Body Mount Bracket. I had to use a flat-head screwdriver to completely seat it. I did first

temporarily mount the camera using duct tape and just ran the camera wire through the open passenger window to test the viewing angle before permanently mounting it.

Before permanently mounting the camera, I cleaned the area with isopropyl alcohol and attached the camera with the supplied 3M adhesive pad. At some point I will drill a couple holes into the body mount bracket and additionally secure the camera with either a zip tie or screws.



The camera wire was run up to the back corner of the engine bay next to the passenger side firewall the same as camera #2 previously shown. After that I ran them both across the back of the engine bay over to the driver's side firewall. I don't know what those plastic brackets are called, but I fed the wires through there. If you can't get the connector through the opening, just loosen the nut on top using a 10mm socket.



I will cover feeding the camera wires into to cab via the firewall after the camera #3 section.

### Camera 3 – Left A-Pillar Body Mount Bracket Passenger Side

3	Left A-Pillar Body Mount Bracket (Driver side)	Bottom	Forward	Left front tire
---	--	--------	---------	-----------------

Camera #3 is mounted the same as camera #4. The only difference is I didn't need the 20' Camera Extension Cable. The run up to the firewall plug location is short enough for the camera wire to make it all the way inside the cab to the video interface connection.

### Route The Camera Cables

Individually coil the three extension cables, leaving about two feet of length from the end of the free connectors, to be fed into the cab via the firewall hole. Use small zip ties to keep each cable properly coiled to about six inches in diameter.

**NOTE:** Adding a piece tape and notating the camera number on each camera wire connector that feeds into the firewall hole, will make identification from inside the vehicle easier.

Run the camera wire connectors through the firewall hole and into the cab. Feed the end of each camera wire connector through the small end of Daystar Firewall Boot. It might be a little difficult getting the fourth (last) wire through, but it will go.



Slide the boot up along the wires and Insert boot push the boot into the firewall hole until the large end of the boot is fully seated. Now hang each of the three wire coils with a zip tie to the existing wire harness, running along the driver's side of the engine bay.

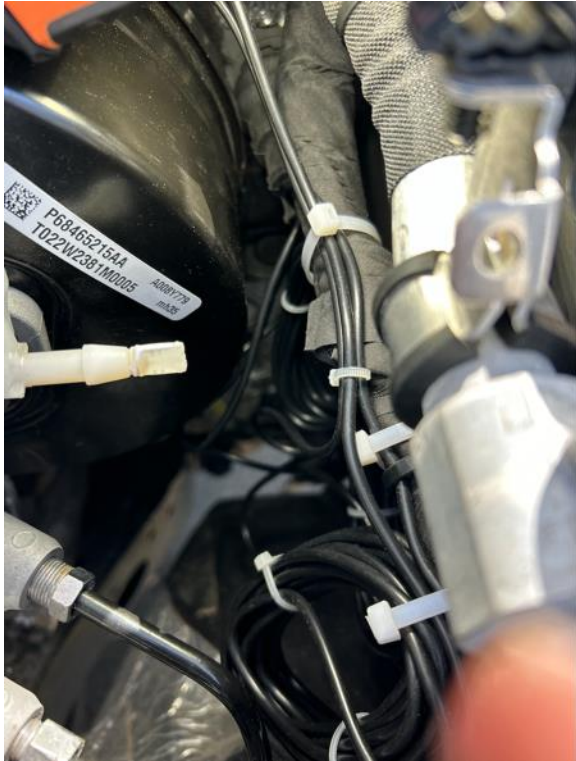

After finishing, zip tie off the narrow end of the boot to seal it.

Plug in each camera wire connector into their associated camera input adapter, which is plugged into the video interface.

### **Configure the Monitor Settings**

Power the camera system up and set the monitor input type to **720p 30fps** from the Settings menu option using either the Menu button on the monitor or the monitor's remote. Now is also a good time to set the date/time on the video interface.

## APPENDIX - Replaced Bullbar Camera with Stinger PHD5N1 Wide-Angle Camera

I later substituted the camera mounted on my bullbar, with the 170-degree angle Stinger HD Universal Camera (PHD5N1). I have seen the cameras included in the kit advertised as being 170-degrees, but they actually appear to 140-degree angle. The below pics are the viewing difference between the two.



*140 Degree View*



*170 Degree View*

Substituting the camera is very straightforward. I just used the standard camera square housing included with the PHD5N1 and mounted it using the existing camera bracket on my bullbar. The only additional task is to cut the blue wire on the connector end to output an AHD 720p video signal.



Here are a couple of short vids as a test of the camera placements:

[Ramp Crawling Camera Test \(youtube.com\)](#)

[Gravel Road Camera Test \(youtube.com\)](#)



## **APPENDIX - Monitor Settings Menu**

Pressing the MENU button on the IR Remote Control will bring up the Settings Menu. Use the arrows to navigate the settings icons. Press OK to select highlighted icon. In the setting sub-menu, use the arrows to highlight or change desired setting and then press OK to save and exit.

### **Loop Time**

Sets recording time for saved video files.

1 / 2 / 3 Minutes

### **Video playback**

it records all 4 cameras on one screen

Normal Video and SOS Video

### **Display delay**

Sets display trigger time when using the Display Triggers to activate the source.

2 / 5 / 15 / 30 Seconds

### **Language**

Sets the language displayed.

### **Input Type**

Sets input video type/resolution.

720p 25fps / 720p 30fps / CVBS PAL / CVBS NTSC

720p 30fps recommended

### **Output Type (to USB stick)**

(Normal Video) = Recorded Percentage used on storage device.

(SOS Video) = Recorded Percentage used on storage device.

### **Clock**

Allows setting the time and date. This is important for time-stamping the recorded video files.

### **Light freq**

50Hz / 60Hz

### **Format**

Formats the Micro SD Card.

This will erase any files on the card!

### **Reset**

Resets setting to factory defaults

### **Version**

Displays current firmware version.

### **Return**

Select to exit the settings menu and return to camera view.

## APPENDIX - microSD Card for DVR

128 GB is the max. size supported by video interface. No matter the size, the DVR will overwrite the oldest recording once the card is full. Here are the estimated recording times based on microSD Card sizes up to 64GB. Obviously, just double the 64GB runtime for 128GB.

### Micro SD Card Rated Capacity Minutes (Hr.:Min.)

Mode	Bitrate	4GB	8GB	16GB	32GB	64GB
720p, 30fps	5.3 Mbps	95 (1:35)	190 (3:10)	380 (6:20)	760 (12:40)	1,530 (25:30)

### Megabits/s to Megabytes/s

5.3 Mbps = 0.6318 MB/s and 1 MB/s equals 8 Mbps, so any Micro SD card with a minimum 1 MB/s write speed will work. That includes even microSD cards made before the class speed ratings were established. I verified this by testing an old 1.0GB card that didn't even have a class speed rating on it.

### Micro SD Speed Class Ratings

C2 (Class 2): minimum write speed of 2MB/s

C4 (Class 4): minimum write speed of 4MB/s

C6 (Class 6): minimum write speed of 6MB/s

C10 (Class 10): minimum write speed of 10MB/s

Sources:

<https://support.garmin.com/en-US/?faq=O0LOsTWhsH8qMrZup8nH19>

<https://www.kingston.com/en/blog/personal-storage/memory-card-speed-classes>

## APPENDIX - Video Interface Display Mode Button

Pressing the Display Mode Button cycles through the 15 various display modes.



Display Mode Button

### Display Modes (Camera Views)

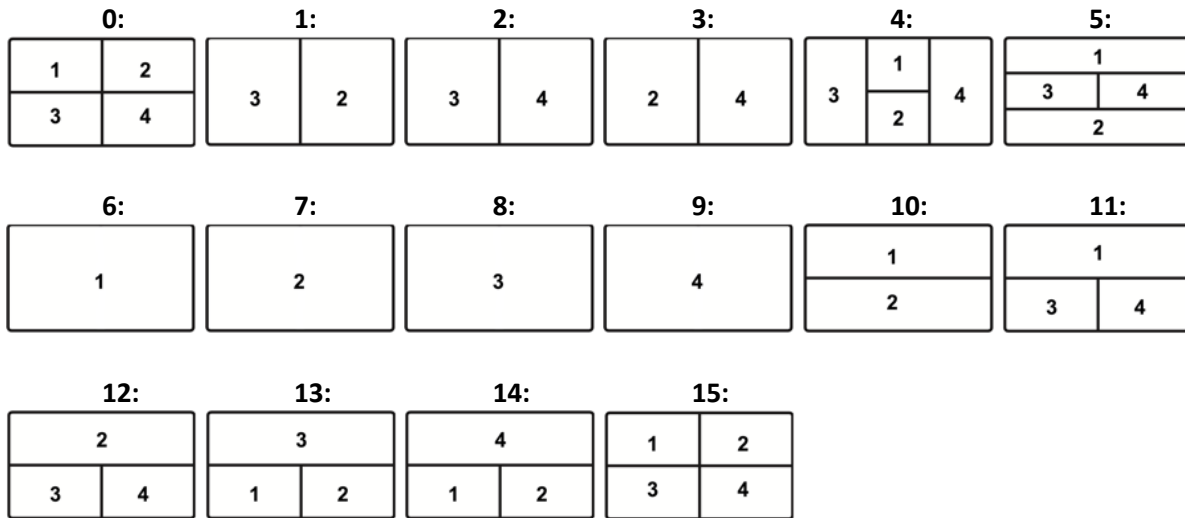

**Note:** The DVR always records the quad-split screen view regardless of what the display mode is set to.

## APPENDIX - Video Interface IR Remote Control

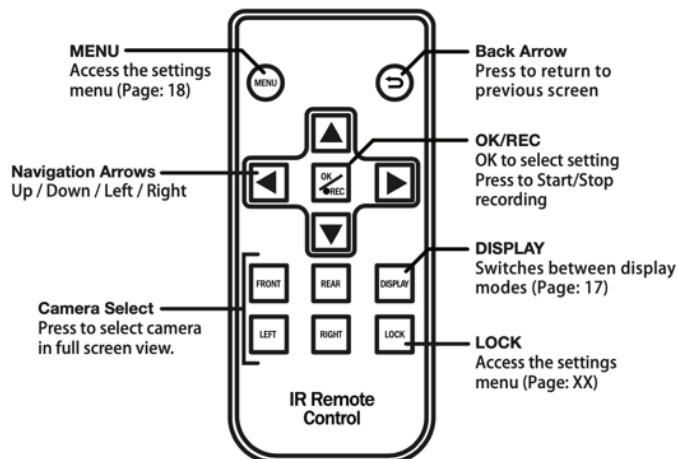

**APPENDIX – My Display Modes Favorites (Camera Views)**

