

# Cascadia 4x4 VSS™ System

## Installation and User Guide

Note: It is imperative that this installation guide is followed **exactly** to ensure that the solar panel bonds properly to the vehicle. Failure to follow this guide exactly could result in an improperly secured solar panel, and a potential failure of the VSS System.

*If you have any questions prior to or during installation*

*please email us at [tech@cascadia4x4.com](mailto:tech@cascadia4x4.com)*

**\*Please read through the entire installation guide before proceeding\***

**Estimated install time = 2 hours**

### **Special notice:**

**You will need 2 people to install the hood vinyl base sheet. Do not attempt to install the vinyl without a helper. Also make sure that the VSS System is installed in a dry environment between 18°→35°C (64°→95°F). Stay out of direct sunlight during install if you can.**

**\*Do not bend the solar panel\***

**\*This is a general guide and will cover all varieties of Cascadia 4x4 VSS System models.**

# Table of Contents

	Page #
➤ Pre-Installation Checklist.....	3
➤ Step 1: Initial Cleaning and Hood Prep.....	4
➤ Step 2: Vinyl Application.....	5
➤ Step 3: Mounting the Solar Panel.....	10
➤ Step 4: Wiring and Charge Controller.....	14
➤ User Guide/Troubleshooting.....	18

**\*Special note:** Do not bend the solar panel while unpacking, or during install. You risk cracking the solar cells inside and damaging the panel. However, once the panel is mounted it will be extremely durable.



## Pre-Installation Checklist

*Before beginning, unpack your VSS System and check for all included components. **Be careful not to excessively bend the solar panel**, try to keep it as straight/flat as possible. Also make sure you have a dry environment to work in – inside a garage is best, out of direct sunlight. The ambient temperature must be between 18°→35°C (64°→95°F). If it's too cold the adhesive **will not cure properly**.*

**Packing list:** *\*Check to see that all of the following items came with your VSS System. (If you ordered the complete, recommended system).*

- 1 Solar panel (with pre-installed 3M VHB tape). **Don't bend the panel!**
- 1 hood vinyl base sheet.
- 1 MPPT solar charge controller (pre-wired and with pre-installed 3M VHB tape).
- 1 vinyl application squeegee.
- 6 zip-tie mounts.
- 10 zip-ties.
- 2 packs of 3M adhesion promoter.

**Required tools:** *\*Make sure you have the following tools handy.*

- Electric heat gun.
- Spray bottle.
- Dish Soap.
- Cleaning alcohol (isopropyl alcohol).
- Multiple paper towels, clean rags or microfiber cloths.
- Ruler/measuring tape.
- Utility knife.
- Latex/nitrile gloves

*The hardest part of the VSS System install is installing the hood vinyl base sheet. If you are not confident doing this yourself please enlist the help of a professional shop.*

*Make sure **you have another person to help you** to peel and place the vinyl. **Take your time.** The vinyl acts as a base-layer to protect your hood.*

## **Step 1 – Initial Cleaning and Hood Prep**

*\*Before proceeding make sure to remove any pre-existing hood vinyls/decals from your vehicle. The VSS System will not bond properly to these.*

- A) Thoroughly wash the hood of your vehicle using soap and water. Make sure to remove all dirt, grime, sap etc. Let it dry, then wipe it down again with alcohol. The hood needs to be **impeccably clean.**

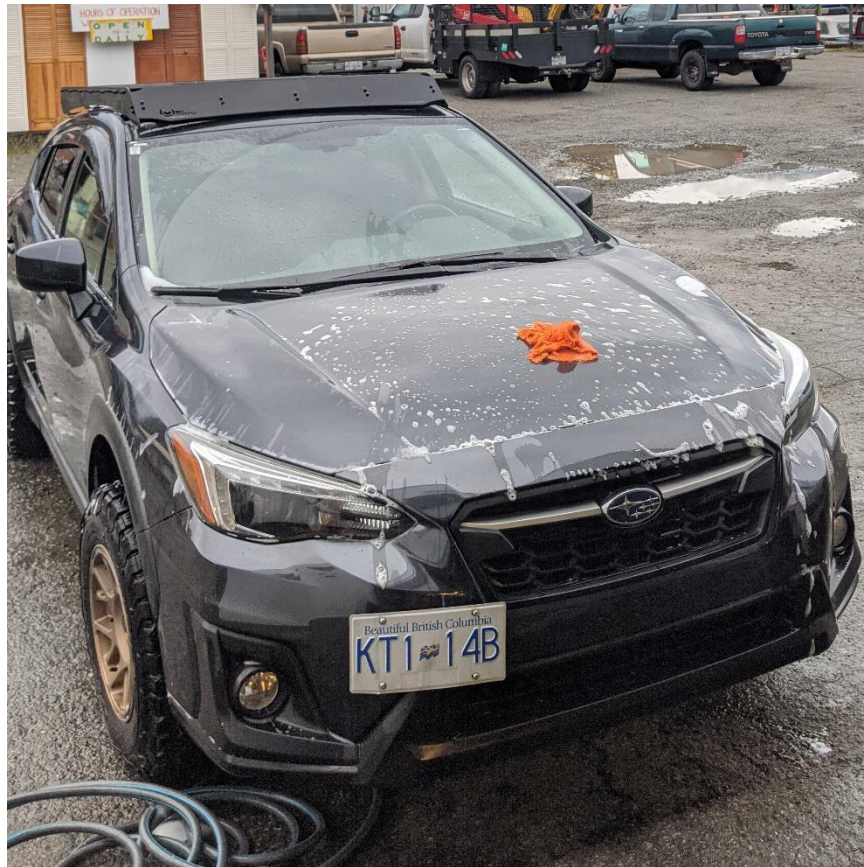

*\*Scrub-a-dub-dub! Get all that dirt, sticky tree sap, and dead bugs off your hood!*

- B) Let dry.
- C) At this point make sure the ambient air temperature is at least 18° degrees Celsius (64°F) and not hotter than about 35° degree Celsius (95°F). If it's hot outside **stay out of direct sunlight.** We strongly recommend that you drive the vehicle into a temperature-controlled garage.

*Continued on next page...*

D) *\*Step D only applies to Jeep Wrangler JK\**

- If you are installing the VSS System on a **Jeep Wrangler JK** you will now have to remove the 2 rubber hood bumpers (black rubber circles on top of hood), and the footman loop. You will not be reinstalling them.
  - If your JK has an under-hood pad you will need to remove a few of the retaining clips with a flathead screwdriver or a v-notch panel puller in order to grant access to the bases of the rubber bumpers and footman loop. The rubber bumpers are removed easily by squeezing their bases and pushing them up through the hood. The footman loop requires the removal of the nuts that hold it in place.
- E) Wash the hood again with rubbing alcohol and a clean rag. Let dry.

*Continue Installation on next page...*

## **Step 2 – Vinyl Application**

The vinyl has been precisely cut to be 30mm (~1.2") smaller than the solar panel. This is so that the 3M double-sided tape adheres **directly to the hood**, and not the vinyl. This scenario provides the most reliable bond.

**If you did not order the complete VSS System (with vinyl), then skip to step 3.**

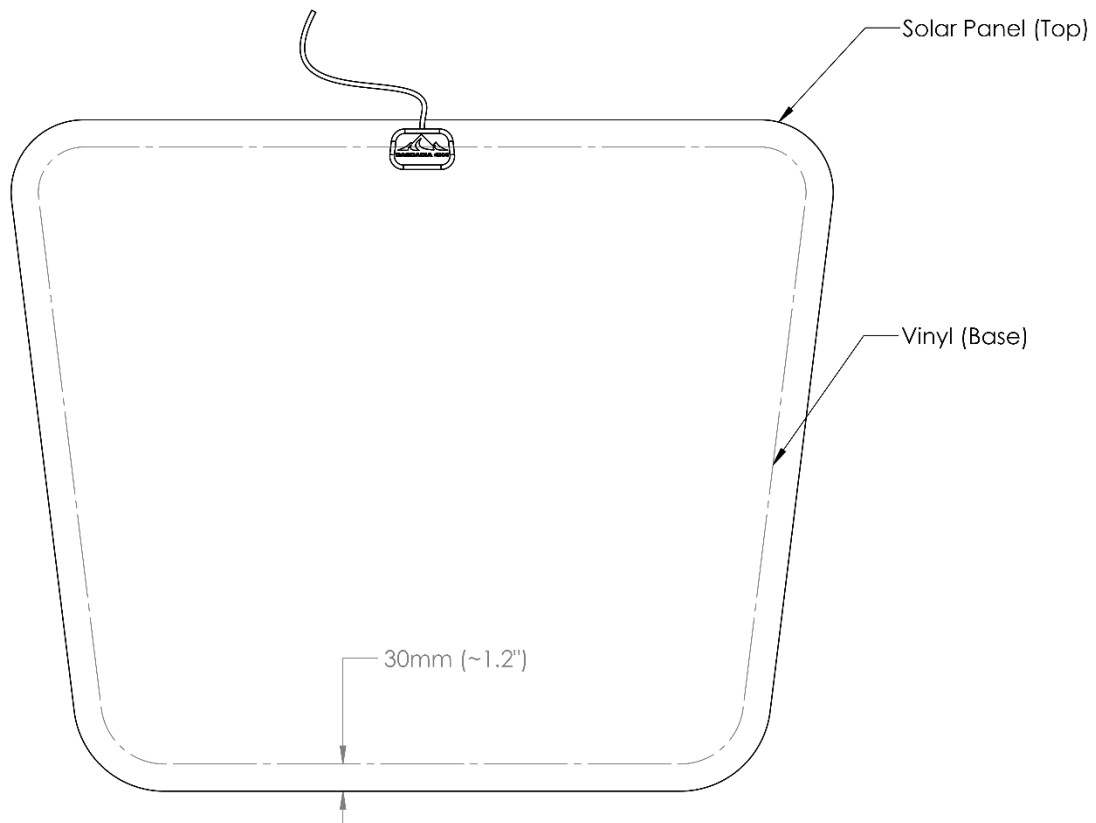

*Continued on next page...*

- A) Unpack the vinyl from its tube. Unravel it and lay it on a clean surface to flatten it out a bit (paper side down). Laying the solar panel or box on top of it will help. Remember not to bend the solar panel. This will make things easier in later steps when it comes time to peel and mount the vinyl.

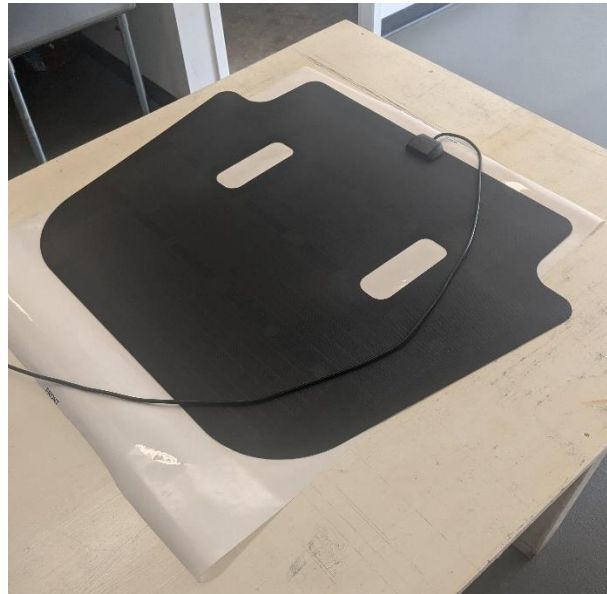

*\*Notice the flattening in action above.*

- B) Mix a few drops of dish soap with some water in a spray bottle. This is the mounting solution. Spray the hood with the soap/water mixture. Make sure the entire hood is covered with soapy water, the more the better! Seriously, douse it. Don't be shy. You want to be able to slide the vinyl easily in the next step, so spray a lot of soap.

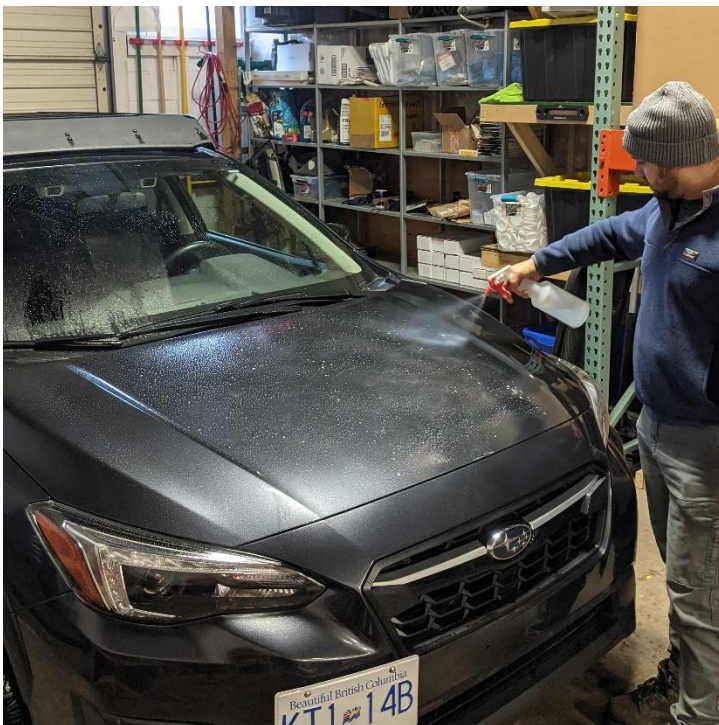

*\*The wetter the better. - Dave*

*Continued on next page...*

- C) Locate your now slightly flattened vinyl base sheet. Note the orientation of the vinyl. Make sure you understand how the vinyl will go onto the hood before you peel it off the white back-sheet. Understand that you will be placing the vinyl and panel on the flattest and most central part of your hood. **Ensure that there is a minimum 30mm (~1.2") gap of mounting surface extending past the vinyl, because this is how much larger the solar panel is than the vinyl.**

*\*Certain models of the VSS System (JK, JL, LR3, FJ etc... have cutouts in the vinyl and solar panel for the windshield washer nozzles. Let these be your guide for installation. All other models will require a ruler/tape measure to find the most ideal central/**flattest** spot on the hood.*

- D) **With two people** hold the vinyl vertically and slowly and gently peel it off of its white back-sheet. **Make sure it does not stick to itself...** (If it does stick to itself you can usually rescue it by pulling it apart gently), spray down the adhesive side of the vinyl with more soapy water from your spray bottle.



*\*4 hands are better than 2.*

*Continued on next page...*

- E) Lay the vinyl on the hood (do not press it into place yet), there should be enough soapy water on the hood that the vinyl can **slide around easily**.



*\*Dave using his keen eye and flawless, robot-like coordination to gently lay the vinyl on the hood of his Tacoma. Note: Your vinyl colour may vary.*

- F) Move the vinyl into place by pulling on the edges with your fingers. Try to get it as centered as possible on the flattest part of the hood. Take your time. If the vinyl starts sticking just lift it a bit (gently) and spray the hood down with more soapy water. Don't panic if it doesn't go on perfectly the first time. Also ensure that there is at least 30mm (~1.2") of mounting surface extending past the edges of the vinyl.
- **\*For VSS System models with windshield washer nozzle cutouts (JK/JL etc.)** – use the cutouts for the windshield washer nozzles as your centering guides. Make sure that you position the vinyl in such a way that you **leave a bit more room in front (windshield side) of the sprayer holes than behind**. This will prevent the spray from the nozzle hitting the solar panel once it is mounted. See image below.



- **\*For all other models:** use a tape measure/ruler to center the vinyl on the hood. This is where your solar panel will sit in the future so make sure you are locating the vinyl on the flattest part of the hood. **Remember that the solar panel will extend 30mm (~1.2") past the vinyl so leave room!**



*\*Take your time positioning the vinyl, as this will dictate where the solar panel will sit. Pick multiple points of reference (edges of hood, body lines, etc.) and measure to them in order to get the vinyl centered. Remember to keep a minimum 30mm (~1.2") gap of mounting surface past the vinyl...**Or you're gonna have a bad time.***

- G) Once you are satisfied with the position of the vinyl locate the supplied vinyl application squeegee card.



- H) Using the squeegee card start with gentle passes from the center of the vinyl to the edge to start the process of removing the soapy water from underneath. Be gentle here and make sure the vinyl does not move and remains flat against the hood.

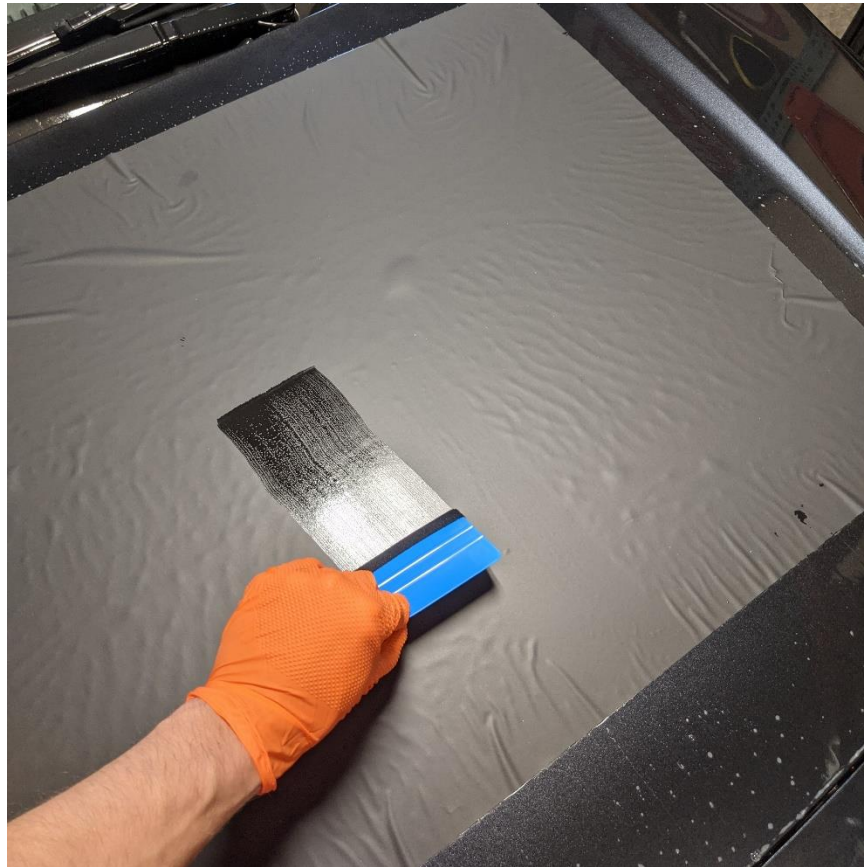

*\*Start making gentle passes from the center to the edge of the vinyl. If your VSS System has washer nozzle cutouts then begin making the passes from there.*

- I) Continue gently making passes with the squeegee from the center of the vinyl to the edge, removing more water and air each time. Go over the entire vinyl in this manner.

*Continued on next page...*

- J) Now that the bulk of the water is removed be more aggressive with the squeegee. Use firm pressure now to remove all remaining water and air from underneath the vinyl.



- K) Gently go over the vinyl with a heat gun (don't melt it!) and the squeegee card to remove all remaining air pockets. Make sure to go over the entire vinyl with the heat gun as it will make new air pockets appear that you can then remove with the squeegee.



*\*Hasta la vista, bubble.*

*Continued on next page...*

- L) Go over the vinyl once more with the heat gun to ensure **absolutely all of the water and air trapped underneath is gone** and that it is uniformly adhered to the hood. This is a crucial step to ensuring proper vinyl adhesion.
- M) Rinse the remainder of the soapy water off the hood/vinyl with clean water and dry it off with a clean rag/towel. Let it dry thoroughly for at least 15 minutes before proceeding.



*\*Now your vinyl looks exactly like this, doesn't it? 😊*

If at this stage the vinyl application wasn't perfect and it has a few small wrinkles ... don't panic! You'll be covering it up with a solar panel in the next step. If you screwed up big time and destroyed the vinyl just send us an email ([sales@cascadia4x4.com](mailto:sales@cascadia4x4.com)) and we can send you a new vinyl base sheet.

*Continue Installation on next page...*

## Step 3 – Mounting the Solar Panel

*The solar panel mounts directly to the hood using its pre-installed 3M double-sided VHB tape and a very critical product known as “adhesion promoter”. The VHB tape is the same class of adhesive used to attach the windows onto the sides of skyscrapers, so don’t worry about it coming off. Just be sure to follow the instructions below to guarantee a solid bond.*

- A) Clean the now installed vinyl base sheet (and hood) with rubbing alcohol and a clean rag. Make sure the entire vinyl and **area where the solar panel will be mounting around it** is as clean as possible. Let dry for 10 minutes.
  
- B) Pick up the solar panel (**keep it as flat as possible**) and lay it down over the vinyl to test fit it. Don’t peel the adhesive yet, you are just getting it test-fitted so that you can **apply adhesion promoter in a later step**. The solar panel is centered when all of its edges extend 30mm (~1.2”) beyond the edge of the vinyl. Slide a ruler underneath the panel to the edge of the vinyl to get this measurement approximately on each side.

If you didn’t order the vinyl base sheet, lay the panel down on the hood anyways to get an idea of where you will be mounting it. Proceed to step 3D.

**\*For VSS System models with windshield washer nozzle cutouts (JK/JL etc.) – use the cutouts for the windshield washer nozzles as your centering guides. Make sure that you position the vinyl in such a way that you leave a bit more room in front (windshield side) of the sprayer holes than behind. This will prevent the spray from the nozzle hitting the solar panel once it is mounted. See Step 2F.**

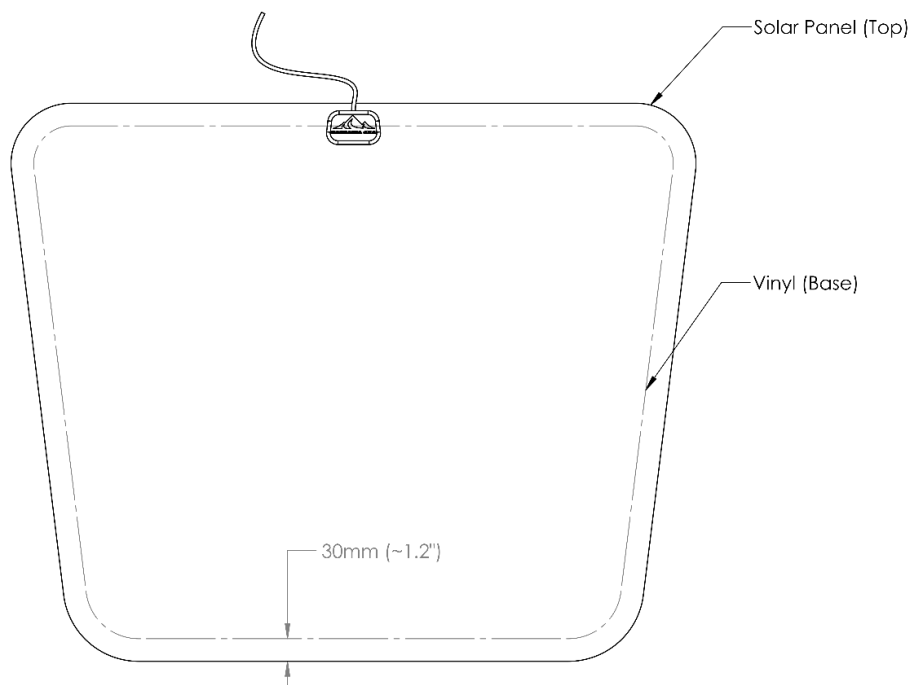

C) **Step C** only applies to you if you installed the vinyl base sheet in previous steps:

- Remove the panel you were test fitting. Make sure the mounting surface is still clean (if it isn't then clean again with alcohol and let dry).
- Locate the 2 packages of **3M adhesion promoter** and use it to coat a 40mm (~1.6") perimeter around the entire vinyl, directly on the hood. This stuff is fairly strong so you may choose to wear latex/nitrile gloves during application. Be generous, and use both of the packets if necessary. This is where the solar panel will be bonding to. The Adhesion promoter will leave a light blue residue that you will tidy up in later steps. . Let dry for 5 minutes.
- **Proceed to step 3E.**

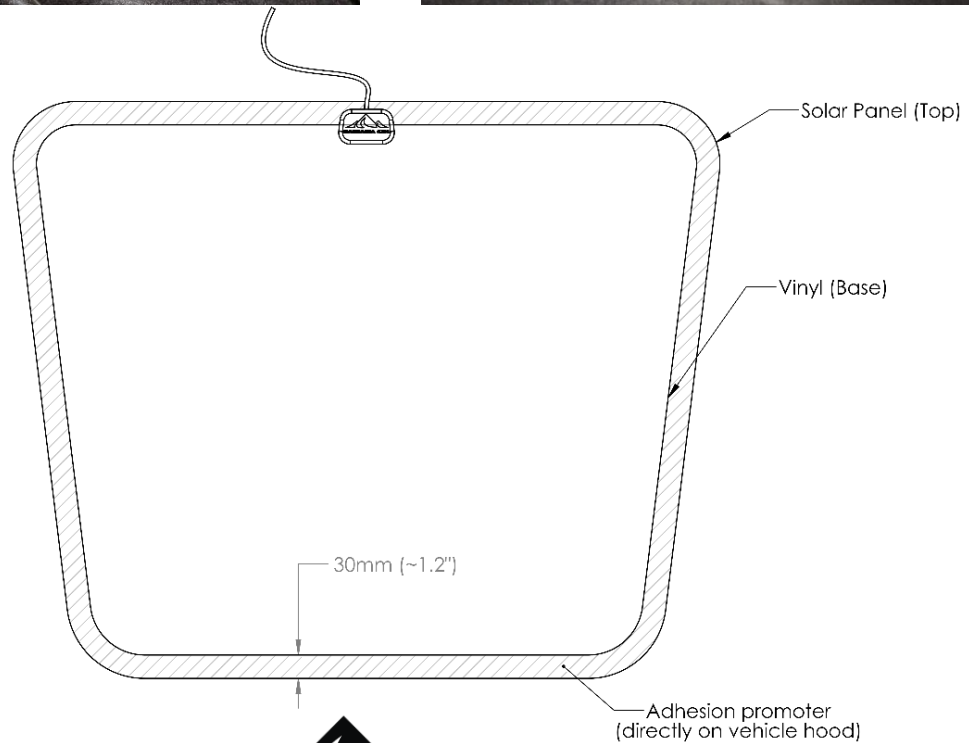
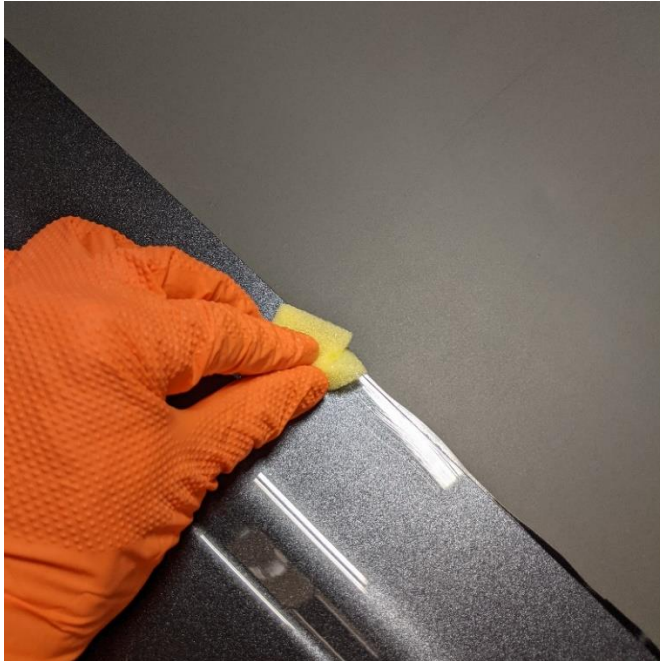

D) **Step D only applies to you if you don't have the vinyl base sheet installed:**

- Place the panel on your hood and move it to the desired position. It may still be on your hood from step 3B. Remember, don't bend the panel!
- In order to determine where to place the adhesion promoter use a ballpoint pen to gently trace the outside edge of the panel onto your hood. You want to be able to see a faint pen line on the hood around the perimeter of the panel when you are done. *We know it seems odd to use a pen on your vehicle but don't worry, it washes off easily later.* If you do not feel comfortable using a pen then you can use painters' tape to trace the edge of the panel, though this method is more time consuming. If you go the tape route then make sure you leave a 6mm (~1/4") gap between the edge of the panel and the tape.
- Now remove the panel from the hood. You should be able to clearly see your pen or tape lines. Locate the 2 packages of **3M adhesion promoter**. This stuff is fairly strong so you may choose to wear latex/nitrile gloves during application. Be generous, and use both of the packets if necessary. Spread the adhesion promoter directly on the hood from the pen/tape line to about 40mm (~1.6") inwards. The Adhesion promoter will leave a light blue-ish residue that you will tidy up in later steps.

***\*Now set a timer for 5 minutes and let the adhesion promoter dry on the hood completely.***

*Continued on next page...*

- E) After you have **waited 5 minutes** for the adhesion promoter to dry on the hood go get your solar panel (be careful not to bend it) and gently flip it over and locate the end of the VHB tape. Using a fingernail or utility knife peel back **only** about 25mm (~1") of the red tape backing and fold it so it pokes out beyond the edge of the panel. See image below. Now there will be 25mm (1") of exposed VHB tape. That's all you need.



- F) Now flip the panel back over right-side up and place it back on the hood/vinyl using your pen/tape line as a guide. If you installed a vinyl, use it as your guide to center the panel. Simply place the panel on top and gently orient it so that you can measure ~30mm (~1.2) from the edge of the panel to the vinyl. Don't worry about the black electrical wire for now.

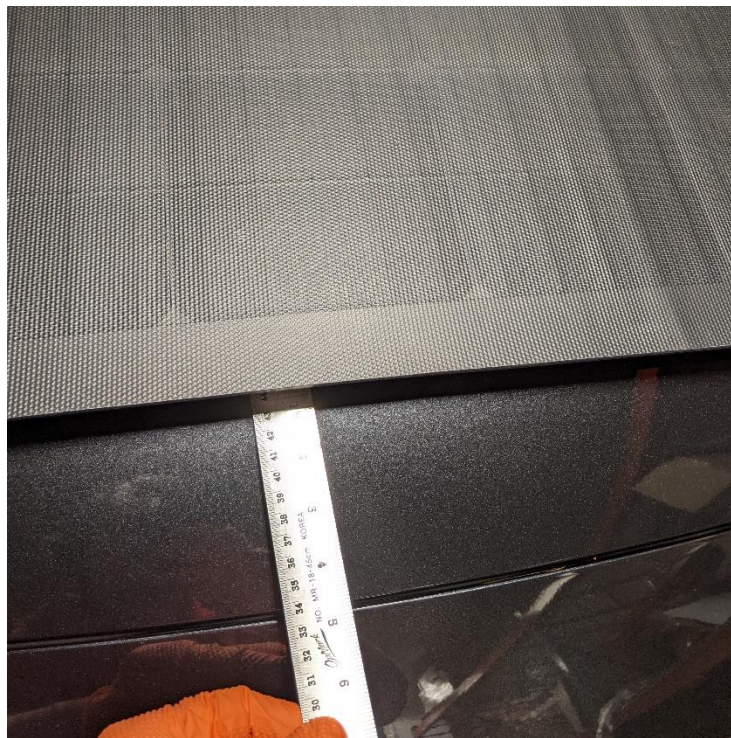

*\*Tired of measuring yet?*

*Continued on next page...*

- G) Once you are 100% sure you have centered the panel into the desired position begin gently tugging on the exposed red tape backing that you folded outwards in Step 3E. Make sure the panel doesn't move.

**\*Don't press down on the initial peeling point until the very end.**

- H) Make sure you hold the panel in position as you pull off the red tape backing. Slowly and gently press the solar panel down at several points **starting about 15cm (~6") from the initial peeling point**. The tape will start to stick.
- I) Once you have **completely removed the red VHB tape backing** begin gently pressing the panel edges down at every point.
- J) By now all the edges of the panel should be stuck to hood. **Spend 10 minutes** (at least) running your hands (using a cloth/rag to reduce friction) along the edges of the panel while pressing down firmly. Be sure to look closely at and under the edges of the panel to make sure there aren't ANY gaps. The edges of the **panel should conform perfectly to the hood**.



*\*Let that rag glide.*

*Continued on next page...*



*\*Don't forget to press down the area behind the junction box.*

- K) Use a little bit of rubbing alcohol on a rag to clean up any adhesion promoter residue around the panel.

**\*Do not expose the solar panel to rainy/snowy conditions for at least 1 hour after installation.**

***\*The solar panel is now fully mounted to the hood but double-check that there aren't any gaps. Press down the edges again after you wire it up in the next step.***

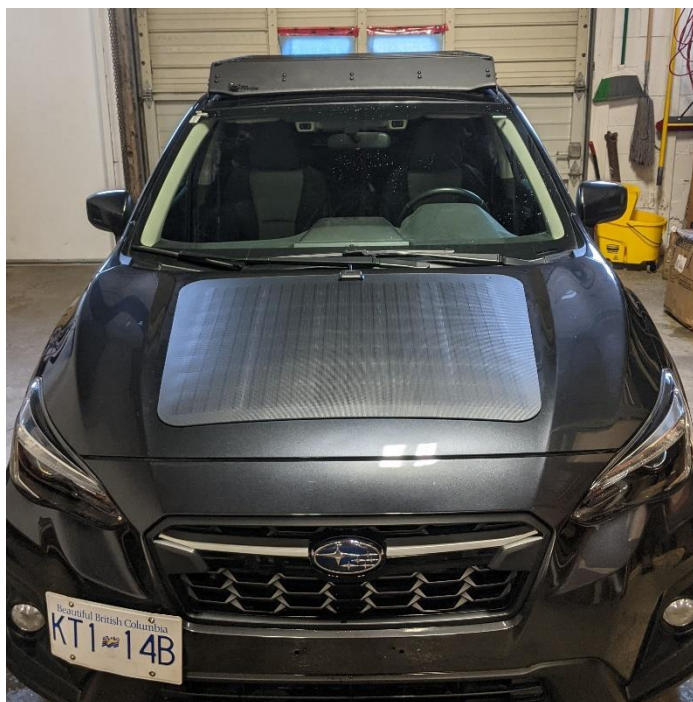

*\*Whether you like Subaru or not, you have to admit... this solar panel looks pretty sweet!*

## Step 4 – Wiring and Charge Controller

- A) Pass the main black solar panel wire (and MC4 connectors) that exit the top of the solar panel into the engine bay. Do this by lifting the hood and passing the wire through the gap that is formed on the windshield side of the hood. Let the wire/connectors dangle in the engine bay for now.

*\*Some vehicles (Jeep Wrangler JK and JL) require the hood to be lifted almost to the windshield in order for a large enough gap to form for the MC4 connectors to pass through.*



*\*Cute, reliable, MC4 connectors.*

- B) Locate a suitable location to mount the solar charge controller. In our testing we have found the top of the vehicle's air intake box to be the best location generally. You want to choose an area that receives good air flow and is away from any exhaust headers. The fuse-box is also a good location but ultimately it is up to you. Check that the wiring from the solar panel will reach this location, and that the wiring from the charge controller will reach the battery. The surface also needs to be **smooth, flat, and clean** so that the VHB tape on the charge controller can bond to it.
- C) Test fit the charge controller and check for clearance by making sure you can still close the hood. **Without peeling** the backing off the VHB tape just place the charge controller on top the airbox (or whichever spot you chose) and slowly close the hood. Make sure that you can close the hood without contacting the charge controller.



*\*Above is the preferred mounting location for the charge controller on the air intake box on the **Jeep Wrangler JL**.*



*\*Above is the charge controller mounted on the air intake box of a **Jeep Wrangler JK**.*

- D) Once you have decided on a charge controller mounting location it is time to clean the mounting surface. Use soap and water to remove any dirt/grime. Let it dry thoroughly. Then go over it again with rubbing alcohol. You may need to scrub vigorously to remove all the dirt and oil from the surface. This is a very important step to ensure a secure bond. Make sure the mounting surface dries fully.

- E) Now fully peel back the backing tape on the 2 strips of 3M VHB tape found on the base of the charge controller. Place the charge controller in the desired position and press down firmly.
- F) Now it's time to route the solar panel wires. The point of doing this is so that the main wire doesn't stick up from the solar panel when you open/close the hood, and so that it looks neat and professional. Use the included square zip-tie mounts and zip-ties to neatly route the main black solar panel wire from the solar panel to the charge controller. This is the wire you passed through the hood gap in step 4A.
- You should attach the zip-tie mounts to the **underside of the hood**. Make sure you clean the mounting surface for the zip-tie mounts with soap and water, and then rubbing alcohol before sticking them on. Use at least 4 zip-tie mounts along the underside of the hood.
  - Make sure the surface for the zip-tie mounts is dry and then stick them on in the desired position. If you have a bit of adhesion promoter left over, use it before placing the zip-tie mounts. Let them **sit for 5-10 minutes** (this is a good time to hit them quickly with a heat gun to help curing) before using zip-ties to attach the main black solar panel wire to them.

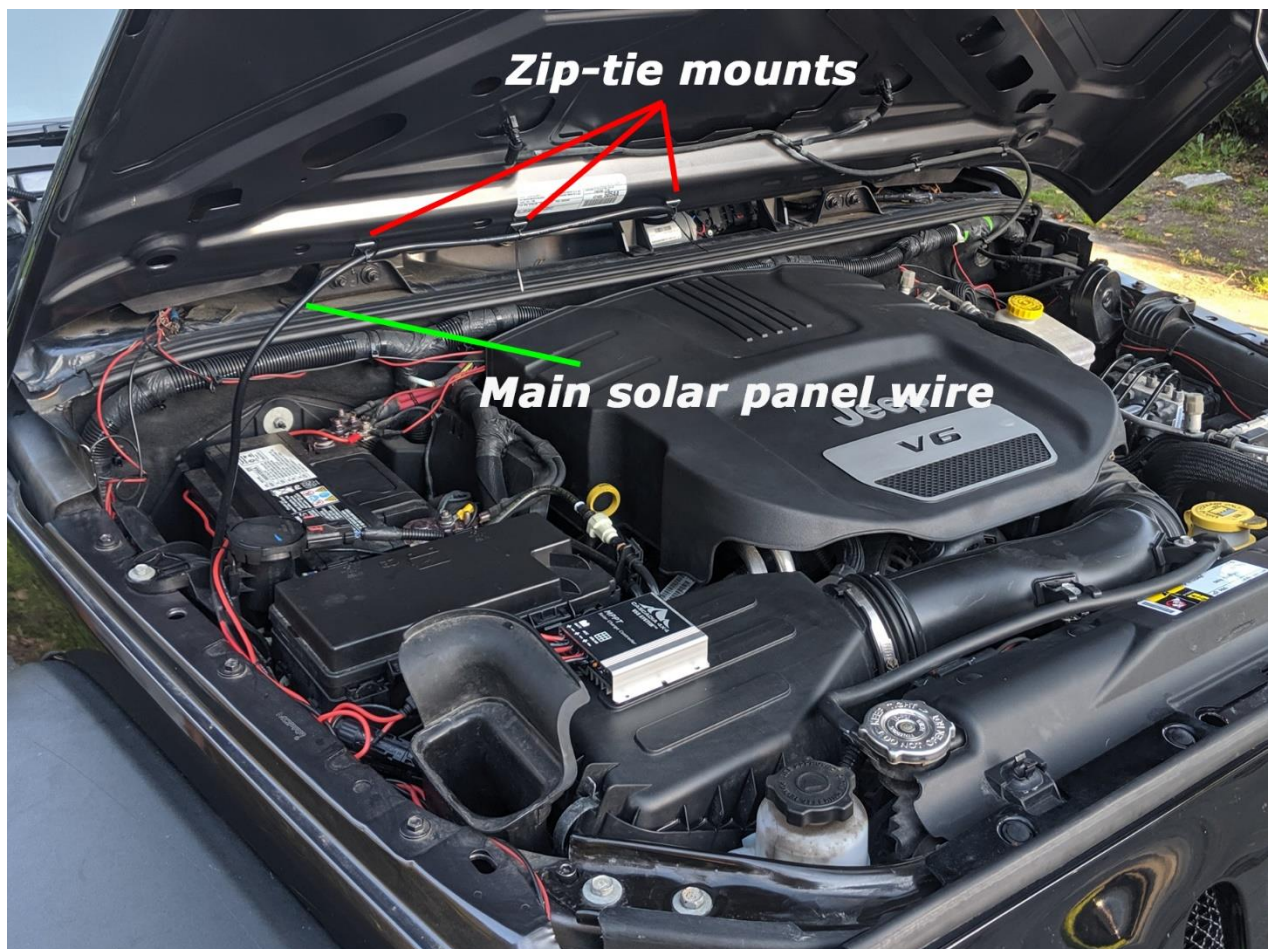

*\*Above is an example of wire routing for the VSS System on a Jeep Wrangler JK.*

- G) Now connect the 2 MC4 connectors from the main black solar panel wire to the 2 MC4 connectors on the charge controller (labeled "SOLAR").

*\*The 2 accessory wires labelled "ACC" can be left alone for now (or forever).*

- H) Now connect the 2 battery wires (labelled "BATT") from the charge controller to your vehicle battery. Simply connect the black wire ring terminal (-) on the charge controller to the negative terminal on your vehicle battery. Then connect the red wire ring terminal (+) to the positive (+) terminal on your vehicle battery. The way you do this is by simply unscrewing the nut on each battery terminal, sliding the ring terminal over the battery terminal stud, and then putting the nut back on and tightening.

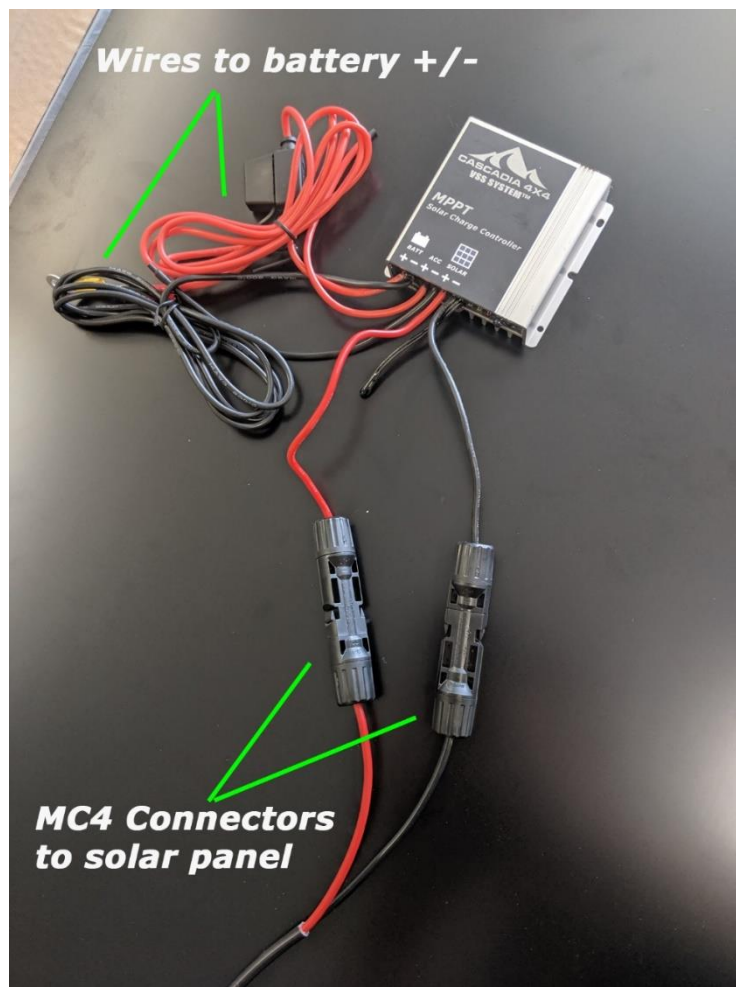

- I) At this point the VSS system is fully wired up. Use the remaining zip-ties to clean up any extra bits of wire. Make sure all wiring is away from the hot parts of the engine where it might melt. The yellow and green lights on the charge controller should be on. When the panel is exposed to sun the green light will start blinking.

# User Guide/Troubleshooting

Once in direct sun the VSS system will start working automatically and require no further input. The unit has been pre-programmed from our factory to work with lead-acid, gel, and AGM batteries. The small green light on the charge controller will start blinking quickly (indicating normal MPPT charging) when sun touches the solar panel and the yellow light will remain on at all times under normal charging operation. The charge controller will automatically stop charging once it senses that the vehicle battery is fully charged to prevent overcharging.

*\*Always remember to run all your 12V accessories through some type of low voltage cut-off. It isn't great for battery to health to drain your battery completely, and repeatedly. Most 12v fridges have this feature built in.*

*\*If the green light on the charge controller isn't blinking when the solar panel is in direct sun simply reset the charge controller by pulling the in-line 15A fuse located on the red wire and then putting it back in. Also make sure to check the MC4 connections, and battery connections. Please refer to the **table below** for an explanation of the LED status.*

*\*Under some very high heat conditions the charge controller will enter into over temperature protection mode. The red light will blink (0.5s/0.5s) until the temperature drops to a safe level. No need to worry.*

The "ACC" black/red wires are for powering up to a 10A accessory and are optional to use. The advantage of using these "ACC" wires to power an accessory is that they provide a **low voltage cut-off** when the battery reaches 11.4V, and will begin providing current again once the battery reaches 12.0V. This is a safe way to power an accessory without the fear of your starter battery voltage dropping too low to start the vehicle.

*Below is an explanation of the LED status of the charge controller:*

LED	Status	Function
Green LED	On	Solar panel is connected but not yet charging
	Fast blinking (0.1s/0.1s)	MPPT charging mode
	Medium blinking (0.5s/0.5s)	Equal/boost charging mode
	Slow blinking (0.5/2s)	Float charging mode
Yellow LED	On	Battery is normal
	Off	Over voltage protection mode
	Fast blinking	Low voltage protection mode
	Slow blinking	Battery voltage is low
Red LED	On	Output power is 0
	Off	Normal operation
	Medium blinking (0.5s/0.5s)	Over temperature protection mode
	Fast blinking (0.1s/0.1s)	Short circuit/over voltage protection mode

Email [tech@cascadia4x4.com](mailto:tech@cascadia4x4.com) for support.

